

88PT25(JOHNSSON)1

Functional Requirements on Communication system for Wind Turbine Applications

Version 0.X

Preliminary version!

31 March, 2001

ENERGI E2



ELFORSK
SVERIGSK ELFÖRSÄDNING FÖR BARNHUS- OCH UTVÄCKNING - ELFORSK - AB



Authors:

Claus Bjerge

Peter Christiansen

Arne Hedevang

Anders Johnsson

Niels Raben

Jörgen Svensson

SEAS Distribution A.m.b.A

Tech-wise A/S

Tech-wise A/S

Vattenfall Utveckling AB

SEAS Distribution A.m.b.A.

SYCON Energikonsult

Contents

GLOSSARY	4
1 INTRODUCTION.....	9
1.1 BACKGROUND	9
1.2 INTENTION.....	9
1.3 PARTICIPANTS	9
2 SCOPE AND OUTLINE OF THE DOCUMENT	10
2.1 SYSTEM DESCRIPTION.....	10
2.2 COMMUNICATION SYSTEM.....	11
2.3 WIND POWER PLANT DATA.....	11
3 DEFINITIONS AND ASSUMPTIONS.....	12
3.1 WIND FARMS	12
3.2 SINGLE WIND TURBINE INSTALLATIONS AND WIND TURBINE CLUSTERS	12
3.3 PARTIES.....	13
4 SYSTEM	14
4.1 GENERAL	14
4.1.1 <i>Data interchange for secondary systems</i>	14
4.2 FUNCTIONS.....	14
4.2.1 <i>Operational functions</i>	14
4.2.2 <i>System management functions</i>	15
4.3 OTHER FUNCTIONS, OUT OF SCOPE	16
4.3.1 <i>Local functionality</i>	16
4.3.2 <i>Voice and visual communication</i>	17
4.3.3 <i>Actor specific functions</i>	17
5 COMMUNICATION.....	18
5.1 BASIC SERVICES.....	18
5.2 DATA TRANSFER PRINCIPLES	18
5.3 DIFFERENT KINDS OF DATA	19
5.4 MAPPING BETWEEN FUNCTIONS AND WAYS OF COMMUNICATION.....	19
5.5 GENERAL REQUIREMENTS FOR ALL DATA KINDS	20
5.6 SECURITY	20
5.6.1 <i>Authentication</i>	20
5.6.2 <i>Data Integrity</i>	21
5.6.3 <i>Data confidentiality</i>	21
5.7 PERFORMANCE.....	21
5.7.1 <i>Time Critical Functions</i>	21

5.7.2	<i>Reliability</i>	22
5.8	COMPATIBILITY WITH EXISTING SYSTEMS	22
6	PLANT DATA	23
6.1	INFORMATION STRUCTURE	23
6.1.1	<i>Example: PICOM</i>	23
6.2	NAMING CONVENTION.....	24
6.2.1	<i>Naming system example</i>	25
6.2.2	<i>Gearbox signal naming example</i>	25
6.3	ANALOGUE SIGNALS	27
6.4	SET POINT COMMANDS	27
6.5	BINARY SIGNALS.....	27
6.6	BINARY CONTROL COMMANDS	27
6.7	ALARMS	28
6.8	EVENTS	28
6.9	COUNTERS.....	28
6.10	TIMERS.....	28
6.11	GROUPED DATA	28
6.11.1	<i>Data structures</i>	28
6.11.2	<i>Time series data</i>	28
6.11.3	<i>Short text messages</i>	28
6.11.4	<i>Files</i>	28
6.12	LOCAL DATA STORAGE AND HANDLING	28
6.12.1	<i>Analogue values</i>	29
6.12.2	<i>Binary values</i>	29
6.12.3	<i>Alarm logging</i>	29
6.12.4	<i>Event log</i>	29
6.12.5	<i>Counters</i>	29
7	REFERENCES	30
8	APPENDICES	31
A:	TECHNICAL SOLUTIONS	31
B:	PROTOCOLS.....	31
C:	DATA LISTS	31
1	APPENDIX A, TECHNICAL SOLUTIONS	1
1.1	INTRODUCTION.....	1
1.2	NETWORK STRUCTURE AND INTERFACES.....	1
1.2.1	<i>Network System 1 (interface level at the individual nodes)</i>	1
1.2.2	<i>Network System 2 (interface level at the Wind Farm Server)</i>	2
1.2.3	<i>Network System 3 (interface to legacy control systems)</i>	2

1.3	COMMUNICATION PROTOCOL STACK FUNCTIONALITY	3
1.3.1	<i>Communication reference model</i>	3
1.3.2	<i>Basic requirements and assumptions</i>	4
1.3.3	<i>Protocol stacks</i>	4
1.3.4	<i>OPC</i>	4
1.3.5	<i>Companion standard profiles IEC 60870-5-101 and -104</i>	5
1.3.6	<i>The MMS Companion standard TASE.2 (ICCP)</i>	5
1.3.7	<i>IEC 61850-X</i>	5
1.4	XML	5
1	APPENDIX B, PROTOCOLS	1
1	APPENDIX C, DATA LIST	1
1.1	PURPOSE	1
1.2	PROPERTIES OF THE DATA	1
1.3	DATA GROUPS (ACCORDANCE SECTION 6.3-6.11)	1
1.4	DATA LIST EXAMPLE	3

Glossary

The definitions of words below are limited to the scope of this document, unless there is a reference indicated. Three dots (...) in the definition text indicate that the original definition text has been shortened. The exact definition can be found in the reference.

Accuracy (for wind turbines)	Specified value of a parameter that represents the uncertainty in the measurement. [1]
Address	Field, or Fields, in a message identifying both the source and / or destination of the message. [3]
Alarm	Information for attracting attention to some abnormal state. [2]
Analogue signal	Signal in the form of a continuously variable value. [2]
Application layer	The top layer, Layer 7, in the ISO Reference Model comprising the interface between the ISO environment and the IED's / user's applications. [3]
Availability	The availability of a unit or system characterises its ability to perform its required function at any given moment. [2]
Availability (for wind turbines)	Ratio of the total number of hours during a certain period, excluding the number of hours that the wind turbine could not be operated due to maintenance or fault situations, to the total number of hours in the period, expressed as a percentage. [1]
Binary state information	Monitored information of the status of operational equipment that is characterised by one of two states, for example on/off. [2]
Check sequence; check sum	Part of a message used for error checking or error correcting purpose. [2]
Client	An IED, or user, that requests data or services from another IED, or user, which thus responds as a server. [3]
Command	Information used to cause a change of state of operational equipment. [2]
Communication stack	A 7 Layer stack, ISO Reference Model, each layer performing a specific functional role in Open Systems Interconnection communication. [3]
Configuration (of a system or device)	A step in system design e.g. selecting of functional units, assigning their locations and defining their interconnections. Configuration is the process setting up the required parameters for a specific application. [3]
Connection	An association established between functional units for conveying information. A connection is established between two IEDs prior to any data exchange. A connection may be of short duration or long term. [3]

Control	Purposeful action on or in a system to meet specified objectives. [2] Note – Control may include monitoring and safeguarding in addition to the control action itself.
Control centre	A control centre is a location where a master station is located. [2]
Control system (for wind turbines)	Sub-system that receives information about the condition of the wind turbine and/or its environment and adjusts the turbine in order to maintain it within its operating limits. [1]
CRC	Cyclic Redundancy Check. A CRC is performed for each frame and the value is included in that frame when it is transmitted. The CRC check calculation may be simple or complex depending on the protocol being used. The CRC value is used by the recipient communication interface to check and if possible correct errors incurred during transmission of that frame. [3]
Data consistency	Measure of conformity of information on variables at different locations in different instants. [2]
Data integrity	The ability of a communication system to deliver data from its originator to its destination with an acceptable residual error rate. [2]
Data Link Layer	Layer 2 of the ISO Reference Model, responsible for the transmission of data over a physical medium. After establishing the link, layer 2 performs data rate control, error detection, contention / collision detection and recovery. [3]
Data object	A reference structure comprised of one or more data items. Used to represent the specific elements of functionality of the device. These data objects may be hierarchical and may be nested to any number of levels. [3]
Data security	Procedures and actions designed to prevent the unauthorised disclosure, transfer, modification or destruction, whether accidental or intentional, of data. [2]
Data type	A defined method of data presentation, for example data type INTEGER for whole numbers or data type OCTET STRING for an assembly of octets. [2]
Device	A mechanism or piece of equipment designed to serve a purpose or perform a function, e.g. Circuit Breaker, Relay or Substation Computer. [3]
Digital measured value	Digital representation of a measured value. [2]
Encryption	The cryptographic transformation of data to produce ciphertext. [2]
Event information	Monitored information on the change of state of operational equipment. [2]

Function	Functions are tasks that are performed in the control centre or the wind power plant by the system. Generally, a function consists of subfunctions that exchange data with each other. Depending on the function definition functions themselves exchange data with other functions. There is no unique allocation of functions or subfunctions to devices. One or more functions may reside in a single device or be distributed among several devices at the same or at different control levels. In minimum, the most functions consist of three subfunctions, i.e. the subfunctions with the core functionality itself, the process interface function and the HMI (human-machine interface) function meaning human access to the function. [No ref.]
Flow control (in the communication sense)	Control of the data transfer rate. [2]
HMI	Human Machine Interface - A Display screen, either part of an IED or as a standalone device, presenting relevant data in a logical format with which the user interacts. An HMI will typically present windows, icons, menus, and pointers, and may include a keypad to enable user access and interaction. [3]
IED	Intelligent Electronic Device - e.g. numeric Protection relay, or Bay controller, or multi-function electronic Meter. An IED may have connections as a client, or as a server, or both, with other IEDs. An IED is, therefore, any device incorporating one or more processors, with the capability to receive, or send, data / control from, or to, an external source. An IED may provide multi-Function capability ... [3]
Interface	A shared boundary between two functional units, defined by functional characteristics, e.g. common physical interconnection characteristics, signal characteristics or other characteristics as appropriate, and the provision of a declared collection of services. [3]
Interoperability	The ability of two, or more, IEDs, from the same or different vendors, to communicate, exchange data and use that information for correct operation. [3]
IP	Internet Protocol - the TCP/IP standard protocol. IP defines the datagram that provides the basis of connectionless packet delivery. It includes control and error message protocol providing the equivalent functions to Network services, Layer 3, of the OSI Reference Model. [3]
Maintenance	The combination of all technical and corresponding administrative actions intended to retain an item in or restore it to a state in which it can perform its required function. [2]
MMS	Manufacturing Message Specification - standard ISO 9506. [3]
Meter reading	A value representing the integrated total of a measurable variable

	(such as energy flow) taken of a specified point in time. [2]
Overall response time	The time interval between the initiation of an event in a sending station and the output, in the same station, of the associated response coming from the receiving station. [2]
Overall transfer time	The time duration by which information is delayed after the actual event in the sending station and until presentation at the receiving station. [2] Note – The overall transfer time includes the delays due to the input peripheral device in the sending station and the corresponding peripheral output device at the receiving station.
Periodic data transmission	Transmission of sets of data that is repeated in equal time intervals. [2]
PICOM	Piece of information for COMmunication. As defined in the approach of CIGRE Working Group 34.03 into data flows within Substations. [3]
Protocol	The rules for communication system operation that must be followed if communication is to be effected. [2]
Quality of Service (QoS)	A set of characteristics of a connection described in terms of quality of service (QoS) parameters, normally negotiated between peer entities. [2]
Reliability	The ability of a functional unit to perform a required function under stated conditions for a stated period of time. [2]
Remote control	Control of an operation from a distance. This involves a link between the control device and the apparatus to be operated. [2]
RTU	Remote Terminal Unit - ..., an RTU acts as an interface between the communication network and the substation equipment. [3]
Server	On a communication network, a server .. provides data, or allows access to its resources.... [3]
Set point command	A command in which the value for the required state of operational equipment is transmitted to a controlled station where it is stored. [2]
Signal	A visual, audible or other indication used to convey information. [2]
Single point information	Monitored information represented by only one bit characterising two determined states of operational equipment. [2]
Spontaneous data transfer	Data transfer initiated by an application process upon events or change of data. [2]
Supervisory Control and Data Acquisition (SCADA)	A system that supervises and controls a geographically distributed process. [2]
Switching command	A command used to change the state of two-state operational equipment from one state to the other state. [2]
TCP/IP	Transmission Control Protocol/Internet Protocol. A suite of

protocols which together provide the functionality up to layer 4, of the ISO OSI Reference Model, without exact layer for layer correspondence. .. [3]

Telecontrol application service element (TASE)	A specific application service element for telecontrol purpose. [2]
Time resolution, limit of accuracy of chronology	The minimum time by which two events must be separated in order that the corresponding time tags be different. [2]
Time tagging	Method of transmission of change-of-state so that transmitted information is accompanied by data giving the registered time at which the change occurred, within the time resolution. [2]
Transmission on demand	A transmission method in which messages are transmitted only as result of a request such as an interrogation command from a control centre or master station. [2]
Transmission quality	A term specifying some quality description of a communication network, e.g. bit error rate, availability of a dedicated channel, probability of bit error bursts, signal to noise ratio, amplitude and phase distortion, non-linearities, inter-channel interference. [2]
Transport Layer	Layer 4 of the ISO OSI Reference Model, acts as an intermediary between the Network and the User application. [3]
Wind farm	A Wind farm is characterised by the size and the location of the wind power plant, i.e. the effects on the power network. Furthermore, the properties and functions of the wind farm are more advanced than of a smaller wind power plant. A wind farm generally has a main controller for co-ordinated control of the individual wind turbines. The wind farm will typically have its own high voltage feeder network with a number of small substations. The electrical properties and behaviour of the wind farm is of such a nature, that it typically will be met with specific requirements regarding power quality and reactive power compensation. In some locations, the wind farm must participate actively in the regulation of the network stability. [No ref.]
Wind power plant	Wind power plant is the general name for one or more wind turbines that converts kinetic energy in the wind into electrical energy within a geographically confined area. [No ref.]
Wind turbine	System that converts kinetic energy in the wind into electrical energy. [1]

1 Introduction

1.1 Background

There are currently many problems with communication systems for wind power plants due to lack of standards and methods. Suppliers usually have their own control system solutions and they are not compatible with others. This is a problem for the users, who obviously want the possibility to manage different wind power systems independently of the supplier. The need for a specification applied to a wind power plant, that shall be supervised and controlled by a SCADA-system, is apparent.

1.2 Intention

The purpose of the specification on functional requirements (“Specification”) is to specify terms for establishment and operation of a system for transfer of data between the controller system in a wind turbine and remote computers. The Specification is intended as guidance during procurement of communication solutions for wind power plants. The Specification may be applied for single wind turbine installations as well as for wind farms. The Specification includes requirements for data transfer and handling, i.e. which data needs to be exchanged and how it shall be done, but not how the data shall be used by the SCADA-system. It is not within the scope of this Specification to describe and specify characteristics of SCADA-systems, HMI, control algorithms etc.

When using specifications on tendering or purchase, it is the responsibility of an employer or user to specify in addition, supplementary or more detailed specifications and whether all or only parts of the Specification shall be applied.

In the appendices of the Specification some of the potential technical solutions that might fulfil the requirements stated in the document are described. However it is not within the purpose of the Specification to make a recommendation on a particular solution or communication protocol.

1.3 Participants

This draft Specification has been prepared by a working group with representatives from the companies: Vattenfall Utveckling AB and Sycon Energikonsult as representatives of Elforsk AB, Sydkraft Vind AB, Tech-wise A/S as representative of Elsam A/S, SEAS Distribution A.m.b.A as representative of Energi E2 A/S.

2 Scope and Outline of the Document

The scope of this specification is communication systems supporting functions mainly for remote operation and supervision of wind power plants. Apart from the functions needed by the operator the system shall support also functions needed by other parties. The functions are further described in Section 4 System.

This chapter explains the different parts of the operational system and how they are defined. The structure of the document is described by Figure 1, where the different subsections correspond with the disposition of the document.

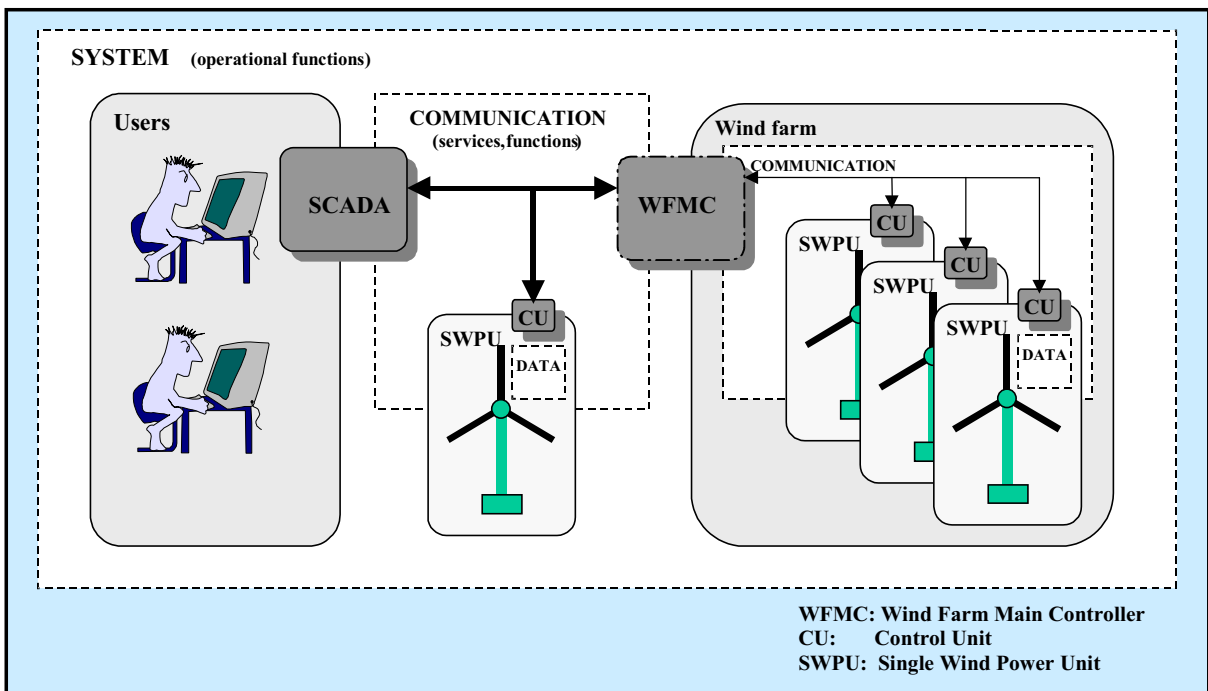

Figure 1: System overview for wind power communication

2.1 System description

On the highest level the system is described from an operational point of view, i.e. the functions needed for remote operation and supervision of wind power plants. The functions are described from a communication point of view. The affected actors and functions are described in Section 4 System.

As depicted in Figure 1, there are both wind farms and single wind turbines. In the case of bigger plants there is usually a wind farm main controller (WFMC) and an internal communication system, which connects all the turbines to the WFMC for further external communication.

2.2 Communication System

In this Specification “communication system” shall be understood as a system for:

- Transfer of data from a process/plant level to a level, where data are accessible for an application in a standardised format
- Transfer of data to a process/plant level for distribution of commands, operational settings etc.

The requirements on the communication system are specified in Section 5 Communication.

Data may also be understood as verbal communication, as in telephone communication, as well as visual communication, as in video communication. The different kinds of data communication need to be able to coexist on the same transmission network.

2.3 Wind Power Plant Data

The different operational functions need access to data in the power plant and the sending and receiving parts must be able to interpret and handle the data. Therefore, the data structure must be defined together with the data types and other characteristics. This is done in Section 6 Plant Data.

3 Definitions and Assumptions

This chapter includes definitions and descriptions on wind power related terms and equipment.

A Wind Turbine is in this context a wind driven generating unit feeding electric power into a grid. The wind turbine is autonomously controlled, which means that all-necessary control and safety systems for proper operation are self-contained. It does not depend on external control devices to perform its basic operations. The wind turbine may however be supervised and controlled by a central system (e.g. a SCADA-system) for co-ordination of more wind turbines and for co-ordination with the electric network. In order to conduct operation and maintenance, a system for supervision and control of the wind turbine(s) is essential, as the wind turbines typically are located remotely and at far distance from the operator.

3.1 Wind Farms

A Wind Farm is characterised by:

- The size and location of the power producing plant, i.e. the effects on the power network. Typically the total installed capacity is of more than 10 MW in one location. The limit is slowly rising with the trend towards larger and larger wind turbines.
- The properties and functions of the wind farm, being more advanced than of a smaller wind power plant. A wind farm generally has a main controller for co-ordinated control of the individual wind turbines.

The wind farm will typically have its own high voltage feeder network with a number of small substations. The electrical properties and behaviour of the wind farm is of such a nature, that it typically will be met with specific requirements regarding power quality and reactive power compensation. In some locations, the wind farm must participate actively in the regulation of the network stability.

The wind farm is typically owned and operated by one or more companies specialised in electrical power production. The approach to operation and maintenance is based on remote supervision and monitoring of the plant with on-line functions and frequent updating of several operational data. The needs for advanced functions will typically increase with the installed capacity of the wind farm. In very large wind farms of 100 MW or more, several parties will be involved in the operation, as the wind farm will have a significant impact on the electrical network.

3.2 Single Wind Turbine Installations and Wind Turbine Clusters

A single wind turbine or a wind turbine cluster is among others characterised by:

- The small size of the power producing plant. A single wind turbine or a wind turbine cluster has minor impact on the power network
- The properties and functions of the wind turbine(s), being rather simple compared to a wind farm.

Typically a single wind turbine or a wind turbine cluster is connected to the grid at medium voltage level. The installation is not of major importance to the grid. The installation will typically have a very simple high voltage feeder to the network. The electrical properties and behaviour of the installation is of such a nature, that it will only be met with moderate requirements regarding power quality and reactive power compensation.

Private individuals, private corporations or electrical power companies often only own a single wind turbine or a wind turbine cluster. The approach to operation and maintenance is based on remote supervision and monitoring of the wind turbine(s) but the amount of operational data needed and the need for update of data is very moderate. The services will typically be based on a requesting system (dial-up) connected to the public telephone network. The need for advanced functions is very modest, as the primary role of the wind turbine(s) is to produce as much electricity as possible. Normally only one or two parties are engaged in operation and maintenance of the wind turbine(s), typically the owner and the operation and maintenance organisation, which in some cases is one and the same.

3.3 Parties

The operators, users and other interested parties requiring services and functions of a communication system will typically be as indicated in the table below.

<i>Party</i>	<i>Wind Farms</i>	<i>Single Wind Turbines and Clusters</i>
Electrical System Operator (Transmission networks of 100 kV or more)	Applicable	Not applicable. Might be relevant in the future if wind turbines will be directly connected to the transmission network.
Electrical Network Operator (Operator of the network at the point of common connection)	Applicable	Not applicable
Wind Turbine Operator (operation & maintenance)	Applicable	Applicable
Owner	Applicable	Applicable
External e.g. Vendors, and “third parties”	Applicable	Applicable

Table 1: Parties and their scope of interest.

4 System

This section describes the parties' functional requirements.

4.1 General

Basically the communication system must assist the operators, users and other interested parties in performing their tasks by provision of services. The system must be flexible in supporting future requirements and future developments. The system must be open in the sense that "anyone shall be able to get information on anything from anywhere", once they have authorisation to the system. The system thus shall be adapted to individual users and services provided accordingly by means of configurations, set-ups etc.

The communication system shall be based on open and widely accepted methods with a high degree of interface possibilities. The system shall be robust and reliable, but the system shall not be used for the safe and secure operation of the plant. Faults in the communication system shall not cause malfunction of an individual wind turbine. The system shall be designed in a way that faults of a sub-system interferes as little as possible with functions of the communication system as a whole.

In designing the system it shall be taken into account, that the physical environment at the plant typically has a wide span of temperature, moisture, salinity and vibration levels.

4.1.1 Data interchange for secondary systems

Secondary systems may be for example Beacons (sea and air), Fire protection, Emergency alarm, Intruder alarm, Power supplies and emergency power systems, Meteorological stations, Safety systems for personnel, Data logger systems and Condition monitoring. Condition monitoring will be very important for offshore wind farms and it will be a standard function in all larger wind turbines.

The condition monitoring system provides status and analysis reports for components. The analysis may be in the form of spectres, trends, statistic figures, time tracking etc.

The values shall be available for display on operator HMI as well as for storage (databases). Updating of values shall be selectable down to an interval of 1 sec. All data must be stored in the plant controller for transmission on demand. Transfer of data from the buffers may be carried out off-line without synchronism with real-time.

4.2 Functions

The basic functions of the system can be grouped in two main categories, Operational or control functions and System management functions.

A third group is Process automation functions, which involve functions that operate with process data directly without the involvement of an operator. However this group is not within the scope of this specification and is not further treated.

4.2.1 Operational functions

The operational functions are needed for the normal daily operation of the wind power plant. In these functions an HMI, either local or remote, is included. The operational functions are

used to present process or system information to an operator or to provide him the control e.g. by commands. The operational functions include the following:

- **Access security management**
Access to operational functions has to be controlled by a set of rules. Access control is to allow the capability to restrict an authenticated client to a pre-determined set of services and objects.
- **Supervision (Wind power plant operation and Network operation)**
Local or remote monitoring of the status and changes of states (indications) for operational devices.
- **Control**
Control function allows an operator or an automatic function to operate equipment like switchgear or transformer, a protection, etc. Control is subject to miscellaneous filters that check that there will be no damage if the control is issued.
- **Parameter changes (parameter set switching, subset of setting, or single parameter)**
In addition to single parameters, an application may have several possible pre-defined parameter sets (but only one active set).
- **Alarm management**
Alarm is generated when a data of the system takes a value that shall be specially considered by the operator, i.e. there is a need for attracting attention to some abnormal state. Alarm management functions allow an operator to visualise, acknowledge and clear alarms.
- **Event and Log management**
Functions for continuous scanning of devices for alarms, operator control actions and changes in state, and for recording the events chronologically with date and time information.
- **Data retrieval of configuration data and settings**
Functions for a follow-up of parameter settings should include services to retrieve all parameters (names, values and units for all setpoints) or to retrieve only those that differ from the default values.
- **Disturbance / fault record retrieval**
Data retrieval for the purpose of display and bulk data storage of fault data.

4.2.2 System management functions

System management functions include both functions for system support and for system configuration and maintenance. System support functions are used to manage the system itself (e.g. Network management, Time synchronisation, and Self-checking of communication equipment). The functions support the total system and have no direct impact on the process.

System configuration or maintenance functions are used to set-up or evolve (maintain) the system. The system configuration and maintenance functions include the setting and changing

of configuration data and the retrieval of configuration information from the system. The most important examples of System Management functions are:

System Support

- Network management
Functions needed to configure and maintain the communication network. The basic task is the identification of communication objects/devices.
- Time synchronisation
Synchronisation of devices within a communication system.
- Self-checking
The self-check detects if an object or device is fully operational, partially operational or not operational.

System Configuration and Maintenance

- Software management
The software management include version control, download, activation and retrieval of software.
- Configuration management
The function is used to download, activate and retrieve configuration data
- Operative mode control
Allows an authorised operator to start and stop functions or objects within the system, including manual activation or reset of subsystems.
- Setting (parameter set)
The setting function allows an operator read and to change on or more parameters affecting the behaviour of the object/device.
- Test mode
Possibility to check a function but avoiding impact on the process (blocking of process outputs).
- System security management
Function to allow control and supervision of the security of the system against unauthorised access or loss of activity.

4.3 Other functions, out of scope

The functions here described are not within the scope of this Specification, that is communication for remote operation. However, from an overall communication system point of view, it can be desired that all communication have to be able to coexist on the same transmission media.

4.3.1 Local functionality

Local system functionality for hook-up for temporary data transmission is not within the scope of this specification. Thus the communication system for remote operation do not need to support functions such as hook-up of portable PC at the plant for Internet access, WEB-cam connection, E-mail service, Program execution, Plant information and Service instructions.

4.3.2 Voice and visual communication

A verbal dialogue system (e.g. telephone) is essential for contacts between operation and maintenance personnel in the wind power plant and the control centre operator. Video communication may also facilitate the co-operation between field personnel and control centre personnel. Video may also be used for supervision of equipment. However these function is not within the scope of this specification.

4.3.3 Actor specific functions

Functions that are of no relevance to the wind power plant or wind turbine operators, the most important actors, are considered to be out of scope. Energy accounting for the network operator is one example.

5 Communication

In this section the requirements on the communication between the different units in the system are specified.

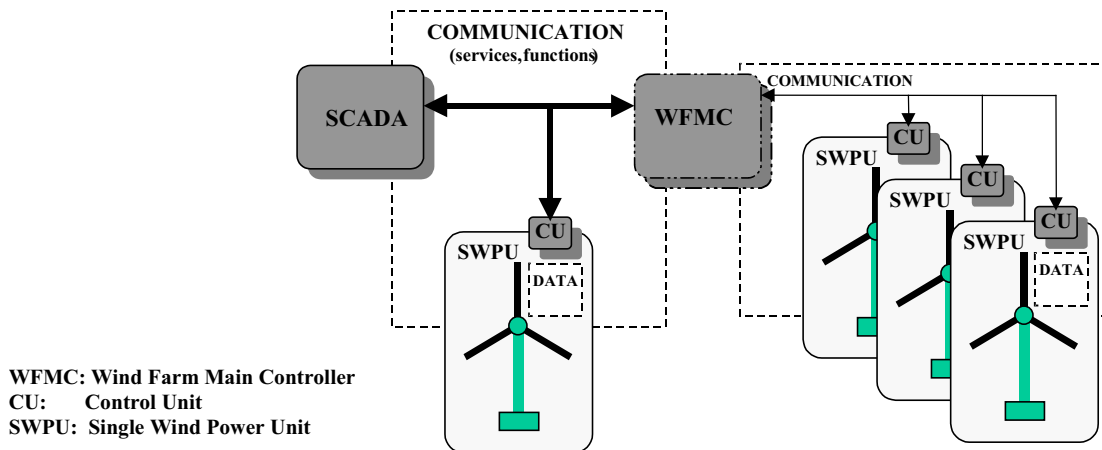

Figure 2: Communication between control units and SCADA

In wind farms a local communication system might be the link between overall control units and the individual wind turbine controller. An overall control unit may be a “wind farm main controller” conducting an overall governing of the plant output and the grid compatibility.

5.1 Basic Services

As stated in Section 2.2 the main objective for the communication system is to transfer data to and from the process/plant level. The overall purpose is to support the functions described in Section 4. In order to accomplish this the basic services of the communication system shall include the following:

- Connection establishment and release
- Authentication
- Identification of functional object and devices
- Data access and transfer
- Reliable communication over a network

5.2 Data Transfer Principles

Data can be transferred according to one of the following principles:

- A. Periodic data transfer (all data or only data that has changed since last transfer)
- B. Data transfer on demand
- C. Event driven (spontaneous) data transfer
- D. Command transfer
- E. Set point transfer

5.3 Different kinds of data

The following kinds of data need to be supported:

- I. Measurements/analogue data (signals) from the wind power plant
- II. Set points sent to the wind power plant
- III. Binary Signals/Status data from the wind power plant.
- IV. Binary control commands to the wind power plant
- V. Alarms
- VI. Events
- VII. Counters
- VIII. Timers
- IX. Data structures
- X. Time series data
- XI. Short text messages
- XII. Flat files

A specific kind of data put specific requirements on the communication system. Alarms, for example, need to reach the remote control centre much faster than events. And the latter is often grouped with other events before transmission. The mapping between the different kinds of data, the data transfer principles and the operational functions are described in section 5.4.

The different kinds of data can be grouped and named real time/on-line data, historical data or forecasts/schedules. On-line data include measurements/analogue data, binary signals/status data (but might also include counters). Historical data include measurement data (calculated values), counters and timers. Schedules could be start/stop schedules for individual wind turbines.

The different kinds of data for wind power applications is further described, in more detail, in Section 6 Plant Data.

5.4 Mapping between functions and ways of communication

Data are either polled at the node (the wind turbine) or periodic and automatic sent out from the node (periodic broadcast and event driven transfer). The important requirement is the 'scanning rate' (maximum delay).

Historical data, counter's and log's are transferred on demand (a request is sent to the wind turbine and the information is send back).

Alarm data shall be sent from the wind turbine on occurrence.

Setting data in the wind turbine and giving orders to the wind turbine are sent to the wind turbine when needed.

<i>Functions</i> (see Section 4.2)	<i>Data kinds</i> (see Section 5.3)	<i>Transfer principles</i> (see Section 5.2)	<i>Comments</i>
<u>Operational Functions</u>			
Access security management	XI	B, D	Encrypted?
Supervision	I, III	A, B, C	
Control	II, IV	D, E	
Parameter changes	II	B, D, E	
Alarm management	V, XI, XII	C	
Event and Log management	VI, XI, XII	A, B, C	
Data retrieval of configuration data and settings	VII, VIII, IX, X, XII	A, B	E.g. historical data
Disturbance / fault record retrieval	IX, X, XII	B	
<u>System Management Functions</u>			
System support	Most	Most	Network mgmt, time synch..
System Configuration and Maintenance	IX, XII	B, E	Mgmt, settings..

Table 2: Possible mapping between functions and ways of communication

5.5 General Requirements for All Data Kinds

1. It should be possible to time stamp all data. Time stamped data shall be stamped with 'last updated date + time' (UTC time). The accuracy and resolution of the timestamp should be at least 10 ms.
2. All analogue measured values should have readable properties like 'signal quality' and 'scanning rate'. This information does not have to be included with every data transfer. The averaging time and the measuring and averaging method should be documented for all data.
3. It should be possible to group both analogue and binary values so they can be read in a single transaction

5.6 Security

Remote monitoring and operation of devices requires strict security measures for several reasons. To protect the data from being stolen, corrupted, and intentionally falsified, to protect the device from unauthorised use or to preserve the privacy of monitoring data.

To enforce these security requirements the following functionality is needed: Authentication, Data Integrity and Data Confidentiality.

5.6.1 Authentication

Server authentication shall ensure the client application that it is truly operating on the intended site. Client authentication ensures that an authorised client/operator is operating the equipment.

The rights for each user to operate functions and to see data on different levels in the object hierarchy might be necessary to set. In that way all users can have relevant access to the system and get updated information from the wind power plants.

5.6.2 Data Integrity

Non-corruption of data transferred is necessary, i.e. the ability of a communication system to deliver data from its originator to its destination with an acceptable residual error rate. This prevents both malicious and false operation.

5.6.3 Data confidentiality

Data items transferred might need to be encrypted to prevent both malicious and false operation, as well as eavesdropping.

5.7 Performance

The response times of most operational functions and, therefore, of the related communication does not need to be much faster than one second (human time scale). System management functions, which shall be available for the operators and control systems, are of low time critical nature. Delay in execution of these functions however should not be more than 2 seconds.

Regarding safety of persons, plant and electric network, the communication system shall not be of critical nature. No functions regarding safety of persons shall be based on the communication system. No functions regarding safety of plant and electrical network shall be based on the communication system – all safety functions must be self-contained in the process or in the devices where systems interface and will trip automatically. In situations where the communication system is completely inaccessible, the plant may be forced to a shutdown by alternative means.

5.7.1 Time Critical Functions

Regarding optimisation of the operation, the communication system has a major role. The time critical functions include both control and supervision functions. Set points for power control and Start and Stop commands are the most time critical functions, but also a prompt response (Acknowledge-on-receive) is important. Periodic on-line operational data is essential for the optimisation of the operation. Finally the operator need to know the status of the communication system to be able to rely on the presented data.

The time critical functions shall use short messages with a high priority. Data-wise the messages shall be small and shall be transmitted with a minimum of delay. Delays may occur due to transmission errors, low capacity or low bandwidth of the transport media or network faults. It is essential for the proper design of the communication system to select methods that minimise such properties.

Time critical functions must be based on fast and reliable transmission of a number of selected data types. An example of a typical requirement regarding delays for these data is as follows:

“The overall transfer time for services in time critical functions shall not be more than 0,5 seconds.”

5.7.2 Reliability

Reliability in the sense that data can be retransmitted, reconstructed, or reprocessed if lost or inaccessible of some reason is essential. Data may be inaccessible e.g. because of faults in the process (plant), faults in data transport or faults in data processing units. For most data it must be possible to restore information, including the sequence of events. Local procedures for recovery may incorporate redundancy of selected functions and backup of data. The communication system shall include functionality to transfer stored data to central storage and processing after restoration of the communication.

To prevent interruptions in the data transfer, the communication system shall allow for redundant communication channels. Processing of data may be carried out simultaneously on more units. Automatic procedures for detection of communication faults and for managing redundancy of system components shall be established. The physical transport media should possibly be redundant to a certain degree depending on the conditions at the specific plant.

5.8 Compatibility with Existing Systems

There must be a way for existing plants to interface to a new communication system. The expected solution to interface systems using proprietary methods for communication, e.g. manufacturer-specified protocols or customer-specified protocols, to new communication systems is to use gateways.

The interface to existing plants will provide a subset of the functions and data specified in this Specification. It should however as far as possible be able to present data on the same HMI and provide as many data as possible for the system databases.

6 Plant data

The following section is a description of principles for representation and storage of data. The description is not specific and thorough, as it does not specify in detail all signals or data that must be available. It is the intention of this description to establish rules and principles for what data and what services shall be available from each wind turbine.

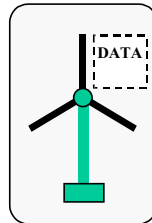

Figure 3: Wind power plant data

The protocol shall have such flexibility that new data can be defined without disturbing old versions of equipment's that comply to a specific version of the specification. A 'naming convention' is described in this specification.

6.1 Information structure

Data is represented by a number of attributes. The number of attributes for a specific data may vary. The number and formats of the attributes sent at configuration time is different than the number and formats of the attributes that is transmitted in any message (data transmission).

Each wind power plant shall have defined the total set of data, the naming, the type and default value of the data according to this specification. The information should be standardised according to the following principles:

- Each device or object shall be self-descriptive (generic part) and the system has to have a function to extract the information contained in the wind power plants objects. It shall be possible to issue an identify request and get a list of all objects in a wind power plant, their names and possibly a short description for each object. It should be possible to get the attributes and services for each object. The list should at minimum include, Name, Type/Kind, Unit, Time requirements, and possibly a short Description.
- For the HMI such information shall be contained in the device using standard readable text, such as ASCII or Unicode (UTF16) (at least optional in the language of the operator). The presentation of the information itself is out of the scope of this specification.
- At least for default naming a hierarchical name structure and an object data dictionary specialised for wind power plants should be used.
- During data transmission the message should at least include the following parts; Name, Value(s), Scan frequency, Time tag and Quality.

6.1.1 Example: PICOM

This section presents one example of an information structure.

To describe the data being exchanged within a substation the CIGRE WG34.03 has introduced the concept of PICOM (Piece of information for Communication). By definition, it is a given data element on a given logical path with given communication attributes. The

PICOM can be compared to a "soft wiring". It is used for defining essential features of communicated data from the application point of view. The main components of a PICOM are summarised mainly by the term's data, type, performance, and path.

Data means the content of the information and its identification as needed by the functions

Type describes the structure of the data, i.e. if it's an analogue or a binary value, if it's a single value or a set of data, etc.

Performance means the permissible transmission time, the data integrity and the method or cause of transmission (e.g. periodic, event driven, on demand).

Path contains the logical source and the logical destination

These PICOMs can be used for data type identification.

PICOM attributes to be transmitted at configuration time only (subscription, negotiation, etc.)

Value for transmission (see above): test or default value if applicable

Attributes for transmission (see above)

Format: data format of the signal : I, UI, R, B, BS, BCD, etc.

Length: the length: i bit, j byte, k word

Accuracy: classes of values

Tag information: if time tagged or not (most data will be time tagged for validation)

Type: analogue, binary, file, etc.

Kind: alarm, event, status, command, etc.

Importance: high, normal, low

Data integrity: the importance of the transmitted information for checks and retransmissions

PICOM and related attributes to be transmitted in any message (data transmission)

Value: value of the information itself if applicable

Name: for identification of the data

Source: where the signal comes from

Sink: where the signal goes

Time tag: absolute time (7 bytes) to identify the age of the data if applicable

Priority of transmission: to be used for input queues or relaying of messages

Time requirements: cycle time or response times to check the validity with help of the time tag

6.2 Naming convention

Communication and objects in the wind power plant shall be object based. Gear and generator could, for instance, be separate objects. Each including measurements, calculated data, and

control services. The system shall be able to manage naming of objects and variables (measurements, etc) in a hierarchical naming system in several levels.

6.2.1 Naming system example

In the following example a naming system with 18 characters is illustrated. The number of characters may, in other naming systems, be extended, e.g. to handle more than 100 wind turbines.

AN NN BBBNN CCNNN DDNN (here 18 characters used)

First group of letters A followed by a number N	Wind power plant, e.g. H1
Second group of numbers with two digits NN	Number within the wind power plant, e.g. 11
Third group of letters BBB followed by two digits NN	Object or system, e.g. gear MCD01
Fourth group of letters CC followed by three digits NNN	Component, e.g. temperature sensor CT003
Fifth group of letters DD followed by two digits NN	Calculated value, e.g. mean value ZA01, or signal, e.g. Input XQ01

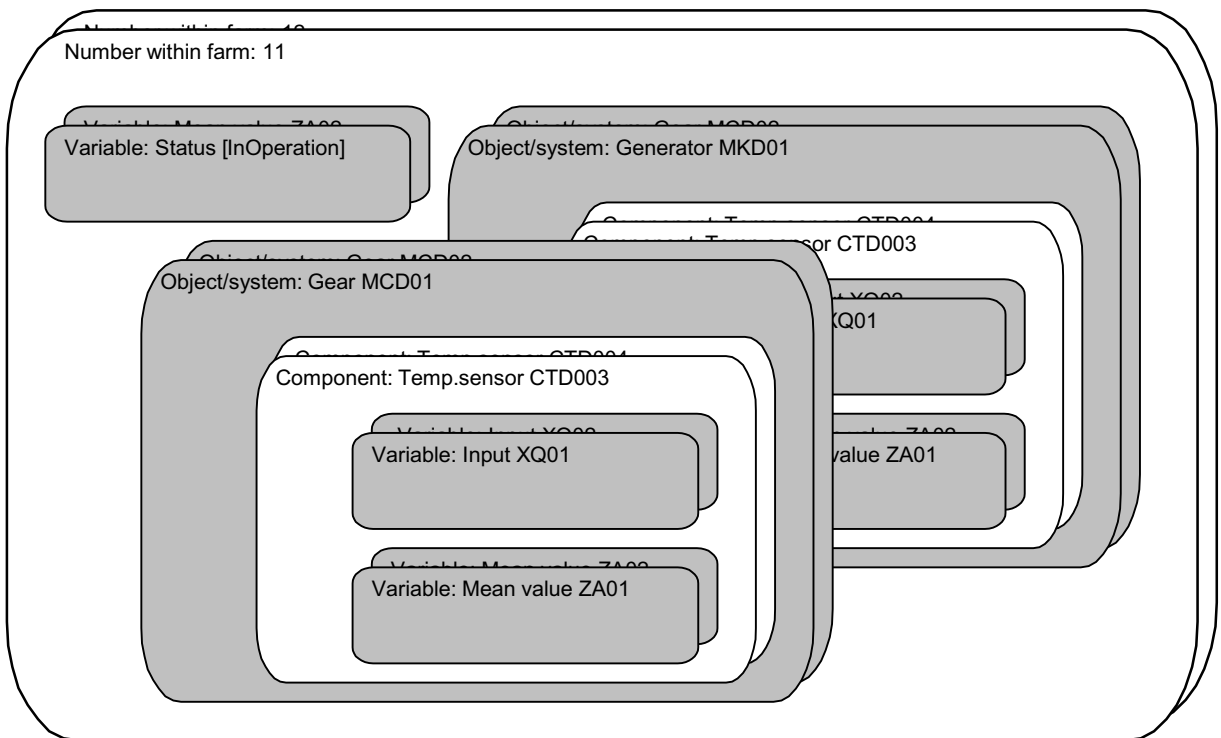

Figure 4: Object model example

6.2.2 Gearbox signal naming example.

The following is a list over the signals available from a gearbox with 3 bearing temperatures, 1 lube oil sump temperature and 3 vibration sensors. The signal list further comprises the gearbox lube oil pump, a sensor for differential pressure over the filter, an oil cooler fan and, finally, an oil temperature sensor after the cooler.

Wind turbine number: 11 Gearbox designation: MCD01

Sensors:

Temperature sensors: CTnnn

Vibration sensors: CYnnn

Pressure sensor: CPnnn

Signals:

Instantaneous value: XA01

Average value: ZA01 (10 minutes based)

Maximum value: ZA02 (10 minutes based)

Minimum value: ZA03 (10 minutes based)

Standard deviation: ZA04 (10 minutes based)

RMS value: ZA21

FFT spectrum: ZA22

FFT-enveloped spectrum ZA23

Binary information: XB01

Signal list example:

11 MCD01 CT001 XA01	LSS main bearing temperature.	Instantaneous value
11 MCD01 CT001 ZA01	LSS main bearing temperature.	10 minute average value
11 MCD01 CT001 ZA02	LSS main bearing temperature.	10 minute maximum value
11 MCD01 CT001 ZA03	LSS main bearing temperature.	10 minute minimum value
11 MCD01 CT001 ZA04	LSS main bearing temperature.	10 minute standard deviation
11 MCD01 CT002 XA01	HSS bearing 1 temperature.	Instantaneous value
11 MCD01 CT002 ZA01	HSS bearing 1 temperature.	10 minute average value
11 MCD01 CT002 ZA02	HSS bearing 1 temperature.	10 minute maximum value
11 MCD01 CT002 ZA03	HSS bearing 1 temperature.	10 minute minimum value
11 MCD01 CT002 ZA04	HSS bearing 1 temperature.	10 minute standard deviation
11 MCD01 CT003 XA01	HSS bearing 2 temperature.	Instantaneous value
11 MCD01 CT003 ZA01	HSS bearing 2 temperature.	10 minute average value
11 MCD01 CT003 ZA02	HSS bearing 2 temperature.	10 minute maximum value
11 MCD01 CT003 ZA03	HSS bearing 2 temperature.	10 minute minimum value
11 MCD01 CT003 ZA04	HSS bearing 2 temperature.	10 minute standard deviation
11 MCD01 CT004 XA01	Oil sump temperature.	Instantaneous value
11 MCD01 CT004 ZA01	Oil sump temperature.	10 minute average value
11 MCD01 CT004 ZA02	Oil sump temperature.	10 minute maximum value
11 MCD01 CT004 ZA03	Oil sump temperature.	10 minute minimum value
11 MCD01 CT004 ZA04	Oil sump temperature.	10 minute standard deviation
11 MCD01 CY001 ZA21	LSS main bearing vibration	RMS total level
11 MCD01 CY001 ZA22	LSS main bearing vibration.	FFT spectrum
11 MCD01 CY001 ZA23	LSS main bearing vibration.	FFT-enveloped spectrum
11 MCD01 CY001 ZA21	HSS bearing 1 vibration	RMS total level
11 MCD01 CY001 ZA22	HSS bearing 1 vibration.	FFT spectrum
11 MCD01 CY001 ZA23	HSS bearing 1 vibration.	FFT-enveloped spectrum

11 MCD01 CY001 ZA21	HSS bearing 2 vibration	RMS total level
11 MCD01 CY001 ZA22	HSS bearing 2 vibration.	FFT spectrum
11 MCD01 CY001 ZA23	HSS bearing 2 vibration.	FFT-enveloped spectrum
11 MCD01 AP001 XB01	Gear lube oil pump.	Operating
11 MCD01 AN001 XB01	Gear oil cooler fan.	Operating
11 MCD01 CP001 XB01	Lube oil filter, diff. pressure.	High
11 MCD01 CT005 XA01	Lube oil temperature after cooler.	Instantaneous value
11 MCD01 CT005 ZA01	Lube oil temperature after cooler.	10 minute average value
11 MCD01 CT005 ZA02	Lube oil temperature after cooler.	10 minute maximum value
11 MCD01 CT005 ZA03	Lube oil temperature after cooler.	10 minute minimum value
11 MCD01 CT005 ZA04	Lube oil temperature after cooler.	10 minute standard deviation

6.3 Analogue Signals

All analogue process values shall be accessible in standard SI-units or other physical units. Analogue values “at the source” shall be available as real-time on-line instant data as well as time averaged values. The values shall be available for display on operator HMI as well as for storage (databases). Updating of analogue on-line values shall be selectable down to an interval of 1 sec. All averaged values must be stored in the plant controller for retransmission on demand. For averaged values the accuracy of the start time of the period shall be better than 10 ms.

Some process values are not required as measurements directly at the source. The values shall be accessible as processed data in a condensed and analysed format. This for instance is the case for condition monitoring of components such as gearbox bearings.

6.4 Set point commands

Values for local functions could be sent as set points. A confirmation of the set point update is required.

6.5 Binary Signals

All binary process values shall be accessible. Binary values shall be available as real-time on-line instant data. The values shall be available for display on operator HMI as well as for storage (databases). The values shall be stored and displayed at level shift with the corresponding date and time tag. Updating of binary on-line values shall be selectable down to an interval of 1 sec.

6.6 Binary control commands

A handshake procedure is required for all commands that start or stop a mechanical component, influence the status or operation mode of the wind turbine or change the software. All other control commands shall give a response with the result of the command.

The binary commands may also include activation and deactivation of programs and parameter changes.

6.7 Alarms

Operational alarms must be transmitted immediately after a triggering. A triggering is typically initiated at any event that results in an automatic stop of the wind turbine, any event that causes an emergency stop or any other alarm-causing event. The alarms shall be available for display on operator HMI as well as for storage (databases).

6.8 Events

Operational events must be stored in an event log in the plant controller for transmission on demand.

6.9 Counters

Counters shall be understood as any value accumulated in time originating in the process such as hour counters, production counters, counters for operational modes, timer's etc. Counters shall be available for display on operator HMI as well as for storage (databases). The values shall be stored with a corresponding date and time tag. Updating of counters shall be selectable down to an interval of 1 sec. All values must be stored in the plant controller for transmission on demand.

6.10 Timers

The timers make it possible to determine the time for the important states in the wind turbine, e.g. Generator on-time, Yawing time and Free to operate time. It should be possible to reset all the timers and the 'Reset date' shall be stored as a separate item.

6.11 Grouped data

Data values can be grouped based on logical relationships between the data, as chronologically ordered data, as text etc. This section includes a description of different ways to put together sets of data.

6.11.1 Data structures

Data structures typically include several kinds of related data, for example the description of an object.

6.11.2 Time series data

Time series data are time based data values for a specific object attribute, for example sampled data, metering data, etc.

6.11.3 Short text messages

It should be possible to exchange text messages between the wind power plant and the control centre using standard readable text, such as ASCII or Unicode (UTF16).

6.11.4 Files

Typically files will be used for upload and download of programs etc.

6.12 Local data storage and handling

The examples in this section are included for informative purpose. Requirements on local data storage and handling do not effect the communication solution.

6.12.1 Analogue values

Selected analogue values shall be stored in FIFO-buffers. The sampling rate of analogue values shall be high enough to characterise events and to determine the cause of faults. A typical sampling rate could be 25 Hz.

The size of the buffers for analogue values shall correspond to a time span starting at 1 minute before a triggering and ending at 1 minute after a triggering. A triggering is initiated at any event that results in an automatic stop of the wind turbine, any event that causes an emergency stop, or any manual stop command (local or remote request).

Additionally it shall be possible to start a scanning of selected analogue values at a sampling rate up to 25 Hz and a selectable duration. The entire mentioned high rate scanning must be stored in the plant controller. Transfer of data in the buffers shall be carried out without synchronism with real-time.

6.12.2 Binary values

All binary values must be stored in the plant controller for retransmission on demand.

Additionally it shall be possible to start a scanning of selected binary values at a selectable duration. All the mentioned scanning must be stored in the plant controller. Transfer of data in the buffers shall be carried out without synchronism with real-time.

6.12.3 Alarm logging

Alarms must be stored in an alarm log. All alarms must be stored in the plant controller for transmission on demand. The buffer depth shall be at least one year. Transfer of data in the buffer shall be carried out without synchronism with real-time.

6.12.4 Event log

The buffer depth of the event log shall be at least one year. Transfer of data in the buffer shall be carried out without synchronism with real-time.

6.12.5 Counters

The buffer size for every counter shall be at least 20 years of operation with 5000 full load hours per year.

7 References

1. IEC 50(415), International Electrotechnical Vocabulary – Chapter 415: Wind Turbine Systems, Terminology
2. IEC 870-1-3, Power System Control and Associated Communications, Glossary
3. IEC61850-02, Communication Networks and Systems in Substations, Glossary

8 Appendices

A: Technical Solutions

Appendix A describes some proposed solutions that should correspond to the specification. The intention is to have these concrete solutions as a guideline for the suppliers affected. It is therefore important that the solutions have been validated against the requirements.

B: Protocols

Some of the suggested protocols, proposed in Appendix A, have been summarised and investigated in this appendix.

C: Data lists

The data from the wind power plant as well as the data sent to the wind power plant are presented as grouped data lists in this appendix.

1 Appendix A, Technical solutions

1.1 Introduction

This appendix present some examples on technical solutions to fulfil the requirements stated in the main document.

1.2 Network structure and interfaces

The communication network on which data transactions shall take place may be organised as one of the following systems:

- Network system with interface at the individual nodes
- Network system with interface at the Wind Farm Server
- Network system with interface to existing older control system/RTU

1.2.1 Network System 1 (interface level at the individual nodes)

The basics of this structure are illustrated in Figure A1. The network structure can be summarised as follow:

1. The network consists of interconnected LAN's. A Wind Farm LAN is established at the wind farm and is connected to an operator LAN. The wind farm LAN is a logical LAN. Any topology is possible.
2. The specifications for data transmission in this specification apply to the individual nodes in the Wind Farm LAN
3. At the individual nodes, the methods for acquisition and compilation of data are conducted on basis of individual, proprietary methods not subject to this specification.
4. Connection to "other" parties (e.g. vendor) is established through gateways to the communication protocol and media of their choice.

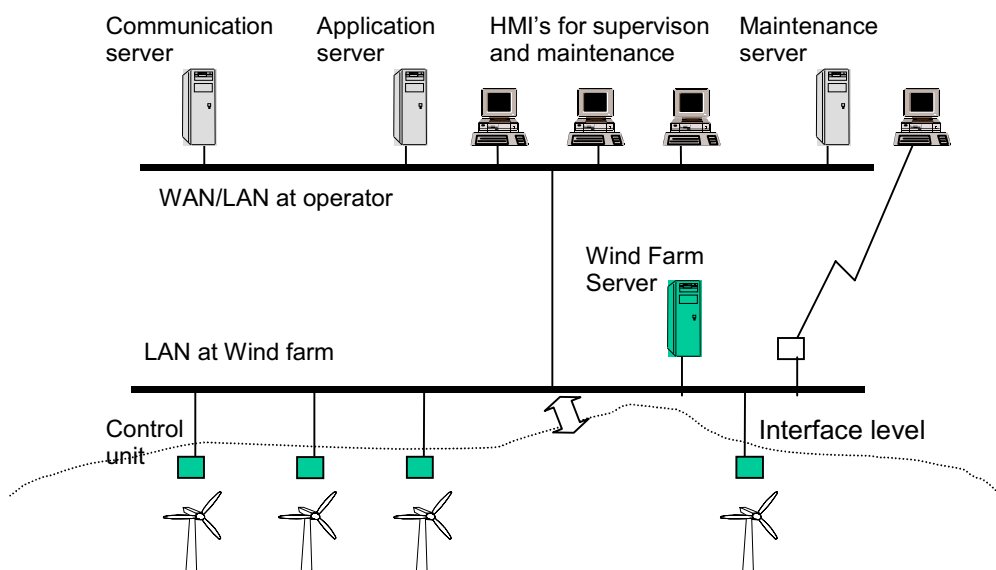

Figure A1: Network System 1. Interface level at the individual nodes.

1.2.2 Network System 2 (interface level at the Wind Farm Server)

The basics of this structure are illustrated in Figure A2. The network structure can be summarised as follow:

1. The network consists of interconnected LAN's. A Wind Farm LAN is established at the wind farm and is connected to an operator LAN
2. A Wind Farm Server is gateway between the Wind Farm LAN and the operator LAN. The server should be transparent for all data necessary for operational or control functions.
3. The specifications for data transmission in this specification apply to the Wind Farm Server but not to the individual nodes in the Wind Farm LAN
4. Methods for acquisition and compilation of data in the Wind Farm are conducted on basis of individual, proprietary methods not subject to this specification, except for functional specifications and requirements due to data properties.
5. Connection to "other" parties (e.g. vendor)

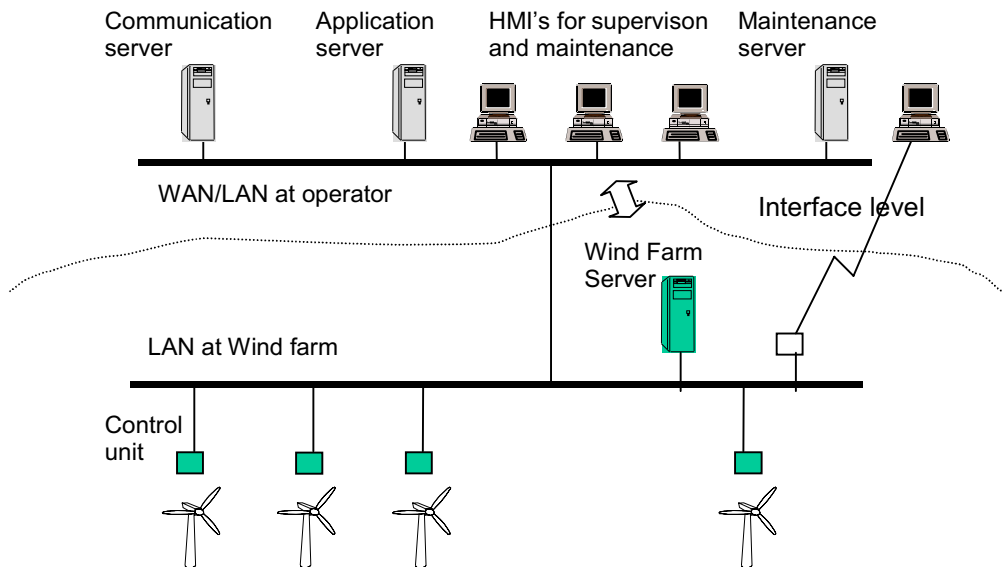

Figure A2. Network System 2. Interface level at the Wind Farm Server.

1.2.3 Network System 3 (interface to legacy control systems)

The basics of this structure are illustrated in Figure A3. The network structure can be summarised as follow:

1. The network consists of dial-up RTUs.

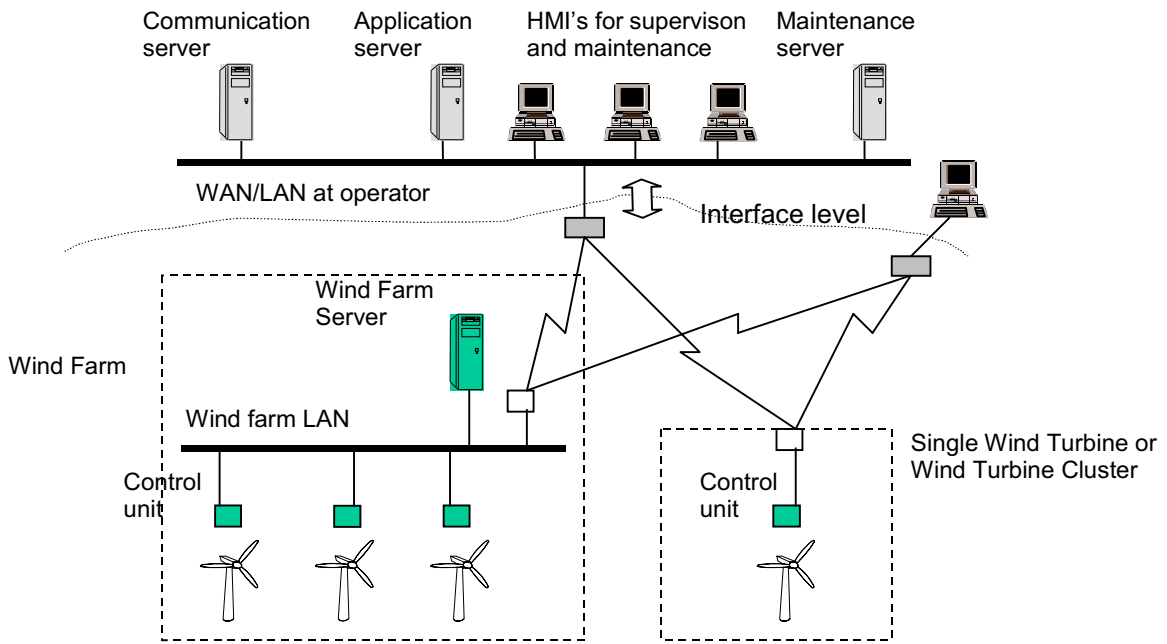

Figure A3. Network System 3. Interface to legacy control system/RTU

1.3 Communication protocol stack functionality

1.3.1 Communication reference model

The layered architectural guidelines of the International Standardisation Organisation (ISO) Open Systems Interconnect (OSI) reference model is here used. The model includes 7 layers as described in Figure A4.

	<i>OSI Layer</i>	<i>Purpose</i>	<i>Services Provided</i>
7	Application	Application Compatibility	Data objects and types, Network services, File transfer.
6	Presentation	Data Interpretation	Encoding of message data
5	Session	Control	Request-Response, Authentication
4	Transport	End-to-End Reliability	End-to-End acknowledgement, Packet Sequencing, Priority
3	Network	Message Delivery	Unicast and Multicast Addressing, Packet routing
2	Link	Media Access and Framing	Framing, Data Encoding, CRC Error Checking, Media Access, Collision Avoidance & Detection, Priority
1	Physical	Electrical Interconnect	Media-specific Interfaces and Modulation Schemes.

Figure A4: The Open Systems Interconnect (OSI) reference model

Layer 4 provides (together with layer 1, 2 and 3) the transport service for the messages defined in layer 7, the Application layer. The transmission protocols could be any one of the standards defined by ISO, such as OSI TP4, the Internet protocol TCP, or any other protocol.

1.3.2 Basic requirements and assumptions

The following requirements and assumptions are basis for the network systems:

- The physical transmission media could be any media, such as direct phone connection (e.g. ISDN or analogue), Internet, GSM, or radio link
- The network is based on Ethernet standards and procedures
- The network shall operate on TCP/IP- standards and procedures
- The system shall allow for several protocols and procedures simultaneously on the same network, e.g. file-transfer shall be possible on the same network simultaneously with data transfer to/from wind turbines
- At each physical location in the network a number of nodes shall be defined. E.g. at a single wind turbine, more than one individual address may be needed to connect to different subsystems.
- Establishment, maintenance and release of connections/associations are to be handled by the communication system.
- The communication system should guarantee with a specified availability that messages are received in the same order as they are sent.
- Message priority may be needed in case of limited capacity.
- Flow control and error control may be provided.

1.3.3 Protocol stacks

<i>OSI Layer</i>	<i>OPC</i>	<i>IEC60870-5-101</i>	<i>IEC60870-5-104</i>	<i>IEC 60870-6</i>		<i>IEC 61850</i>
7 Application	OPC	IEC 60870-5-101	IEC 60870-5-104 User/TCP Interface	IEC 60870-6- 503/702/802		MMS et al.
6 Presentation	DCOM	-	-	ISO 8822/8823		
5 Session		-	-	ISO 8326/8327		
4 Transport	TCP/IP	-	TCP/IP	OSI TP4	TCP/IP	OSI TP4 or TCP/IP
3 Network		-				
2 Link		IEC 60870-5-2 IEC 60870-5-1				
1 Physical		Selected ITU-T Recommend.				

Figure A5: Alternative protocol stacks for different network solutions

1.3.4 OPC

The OPC Specification is a non-proprietary technical specification that defines a set of standard interfaces based upon Microsoft's OLE/COM technology. The application of the OPC standard interface makes possible interoperability between automation/control applications, field systems/devices and business/office applications. OPC (originally OLE for

Process Control) defines a common interface that can be used by HMI, SCADA, Control and custom applications to exchange data with hardware field devices. The specification defines a method for exchanging real time automation data among PC-based clients using Microsoft operating systems. The organisation that manages this standard is the OPC Foundation.

1.3.5 Companion standard profiles IEC 60870-5-101 and -104

IEC 60870-5-101 and -104 are companion standard profiles, particularly aimed at "telecontrol, teleprotection, and associated telecommunications for electric power systems", specifically for RTUs and IED (Intelligent Electronic Devices). The companion standards are composed of a selection of the different recommendations and alternatives provided by IEC 60870-5-1,...,-5. Functionality for IEC 60870-5-101 is related to layers 1,2, and 7 in the OSI model. IEC 60870-5-104 also includes functionality on layer 3 and 4, in order to provide network transport functionality.

1.3.6 The MMS Companion standard TASE.2 (ICCP)

TASE stands for Telecontrol Application Service Element. The name ICCP, which stands for Inter-control Center Communication Protocol is also often used. IEC 60870-6-503 TASE.2 Services and Protocol definitions and –802 Object models for TASE.2 include exchange of telecontrol data, such as real time indications, event notifications and control operations but also other control centre data such as time series, scheduling and accounting information. TASE-2 (ICCP) resides on layer 7 in the OSI-model and is an MMS companion standard, that is, the general MMS services have been particularised for telecontrol applications. The objects to be manipulated have also been defined. As a transport profile TASE.2 can use both OSI-transport protocols for connection-oriented transport, defined in IEC 60870-6-602, and TCP/IP, in accordance with the Internet RFC 1006.

1.3.7 IEC 61850-X

The standard IEC 61850 is being developed by IEC TC 57 Working Groups 10, 11, and 12. The objective is to improve substation device data integration. The standards applied in IEC 61850 (e.g., Ethernet, TCP/IP, XML for system configuration, and MMS) define and exchange real-time data and metadata. IEC 61850 use object models of device functions and device components (logical devices composed of logical nodes and data objects). These models define common data formats, identifiers, and controls, e.g., for substation and feeder devices such as measurement unit, switches, voltage regulators, and protection relays.

The Abstract communication service interface (ACSI, 61850-7-2) provides a common set of communication services for data access, reporting, logging, control applications and related support. The ACSI services are abstract and are mapped to existing communication application layer standards. MMS (ISO 9506) is the service specification applied in 61850-8-1. IEC 61850 includes two primary 7 layer profiles (OSI standards and TCP/IP).

1.4 XML

XML stands for eXtensible Markup Language. XML is a set of rules for defining semantic tags that breaks a document into parts and identify the different parts of the document. It is a meta-markup language that defines a syntax used to define other domain-specific, semantic, structured markup languages. Since XML is non-proprietary and easy to read and write, it's an excellent format for the interchange of data among different applications. The XML data can be transmitted over TCP/IP or other layers like simple RS232. OFX (Open Financial Exchange Format) is an example for an XML definition of data interchange between financial

applications. A format for exchanging data between wind power plants and a control system, named for example Open Windmill Exchange Format (OWX), can be defined. The organization that manages the XML standard is W3C.

1 Appendix B, Protocols

This appendix is included for informative purpose. The list is by no mean exhaustive. There are several protocols missing. For instance the IEC 61850 suite is not described.

On several places a question mark indicate that the authors of this document do not have any information on whether the protocol support that particular requirement. Furthermore, for many of the requirements where there is a yes, no or any other comment, the analysis done is not very extensive. For instance, the comments in this section are not based on results from any practical tests.

	Name of the protocol	OPC	IEC 60870-6/TASE.2 (ICCP)	IEC 60870-5, -101 to -104
A.	Background/ area of use	Process industry	Power system control	Power system control
B.	Applicability	Between client applications and OPC servers on business and process level.	Between control centres (CC) or from CC to stations. Real-time communication.	Between stations and CC. 101 for basic telecontrol, 102 for transmission of integrated totals (metering), 103 for protection equip. 104 for telecontrol over network connection.
C.	Functionality	Data Access, Alarm and Event Handling, Historical Data Access		101/104: status, position, measurements, totals, events, parameter, commands, set point, file transfer
1.	Basic services			
2.	Functional requirements, wind turbine data			
2.1	Function support			
	Operational and Control	Yes	Yes	Yes
	System management	?	Yes	?
2.2	Data transfer principles			
	Periodic data transfer	Yes	Yes	Yes

	Name of the protocol	OPC	IEC 60870-6/TASE.2 (ICCP)	IEC 60870-5, -101 to -104
	Data transfer on demand	Yes	Yes	Yes
	Event driven data transfer	Yes	Yes	Yes
	Command transfer	Yes	Yes	Yes
	Set point transfer	?	?	?
2.3	Transfer of information/data			
	Measurements/analogue values	Yes	Yes	Yes
	Set points	Yes	Yes	Yes
	Binary signals/Status data	Yes	Yes	Yes
	Binary control-commands	Yes	Yes	Yes
	Alarms	Yes	Yes	Yes
	Events	Yes	Yes	Yes
	Counters	?	?	?
	Timers	?	?	?
	Data structures	Yes	Yes	Yes
	Time series data	?	Yes	Yes
	Short text messages	?	Yes	No
	Files	?	Yes	No
2.4	General requirements for all data types			
	Data stamped with 'last updated date + time'.	?	?	?
	Reading of grouped analogue and digital values in a single transaction	?	Yes	Yes

	Name of the protocol	OPC	IEC 60870-6/TASE.2 (ICCP)	IEC 60870-5, -101 to -104
3	Technical requirements			
3.1	Network structure			
	Can operate on TCP/IP	Yes	Yes	No
	Several protocols simultaneously on the same network.	Yes	Yes	Yes, with 104
	Several number of nodes at one physical location in the network.	Yes	Yes	?
3.2	Interface levels			
	At the individual nodes	?	?	Not likely
	At the Wind Farm Server	?	?	?
	To legacy control systems	Only by using protocol gateways	Only by using protocol gateways	Only by using protocol gateways
3.3	Security			
	Authentication	?	Yes	No
	Data integrity	?	Yes	Yes
	Data confidentiality	?	?	No
3.4	Reliability	?	?	?
D	Protocols and services			
	Application/message protocol	OPC	ICCP mapped on MMS. Data access by name.	According to IEC 60870-5-101. No data access by name.
	Transmission protocol	TCP/IP on Ethernet	Transport protocol could be TCP or TP4.	No network protocol for 101-103 (point to point).
	Message priority	?	Yes	?
	Flow control and error	?	Yes	Yes

	Name of the protocol	OPC	IEC 60870-6/TASE.2 (ICCP)	IEC 60870-5, -101 to -104
	control			
E	Performance	?	?	?
F.	Realisations	Thousands of installations all over the world.	Over 100. Chosen for URTICA. Expected to be THE protocol for inter-control centre communication. Newer alternative to IEC 60870-5 for telecontrol. MMS is EPRIs recommended protocol for all real-time communication.	? Based on old solution for remote communication. Heavily supported by German organisations.
G.	Standardisation	Developed and supported by OPC Foundation, a non-profit organisation. Not possible as a de jure standard because it is based on Microsoft's OLE/COM technology which will not be accepted by IEC. It can be considered a de facto standard in Windows environment.	Developed and supported by IEC as an international standard.	Developed and supported by IEC as an international standard.
H.	Products and services	Multiple number of products and good technical support.	Limited number of products and knowledge.	Limited number of products.

1 Appendix C, Data list

1.1 Purpose

This data list is an example included for informative purpose. It is a Danish example and therefore the data descriptions are in Danish. However the authors of this Specification hope that the name of each data is sufficient for understanding the definition of the data.

1.2 Properties of the data

The data can be described by the following properties:

- Name (SignalID)
- Description
- Unit
- Kind (ANalogue SIGnal, SET Point, BINary SIGnal, BINary control COMmand, ALarm, EVent, COUnter, TIMer, data STRUCTure, Time SERie, short TEXT message, FILE)
- Accuracy
- Priority (HIGh, LOw)
- Time tag
- Remark

1.3 Data groups (accordance Section 6.3-6.11)

Analogue signals (ANSIG)

- Analogue signals

Set point commands (SETP)

- Low priority signals - set points
- High priority signals - set points

Binary signals (BINSIG)

- Status (binary)
- Binary signals

Binary control commands (BINCOM)

- Low priority signals – instructions
- High priority signals - binary commands

Alarms and alarm logging (AL)

- Alarms and alarm log

Event and event logging (EV)

- Event log

Counters (COU)

- Counters - number of activations
- Production counters

Timers (TIM)

- Timers (accumulated time)

Data structures (STRUCT)

Time series (SER)

Short text message (TEXT)

File (FILE)

1.4 Data list example

Name (SignalID)	Description	Unit	Value	Kind	Accuracy	Priority	Time tag	Remark.
Analogue signals								
ActivePower	Aktuelle aktive effekt	kW		ANSIG	1%			
ActivePowerPot	Aktuelle potentielle aktive effekt	kW		ANSIG	1%			
AmbTemp	Omgivelsestemperatur	°C		ANSIG	1%			
BladeAngle	Bladvinkel	°		ANSIG	1%			
BrakeTemp	Temp. skivebremse/klodser	°C		ANSIG	1%			
BrakeWear	Bremseslid-måling	%		ANSIG	1%			
CosFi	Cos \square -værdi	-		ANSIG	1%			
Frequency	Netfrekvens (lokalt)	Hz		ANSIG	1%			
GearOilHotSpot	Temp. gear hotspot	°C		ANSIG	1%			
GearOilInTemp	Temp. køleolie-ind	°C		ANSIG	1%			
GearOilOutTemp	Temp. køleolie-ind	°C		ANSIG	1%			
Gen1InTemp	Kølemedietemp. Gen1 ind	°C		ANSIG	1%			
Gen1OutTemp	Kølemedietemp. Gen1 ud	°C		ANSIG	1%			
Gen2InTemp	Kølemedietemp. Gen2 ind	°C		ANSIG	1%			
Gen2OutTemp	Kølemedietemp. Gen2 ud	°C		ANSIG	1%			
Generator1RPM	Generator1 omdrejninger	RPM		ANSIG	1%			
Generator1Temp1	Viklingstemp. Gen1 måling1	°C		ANSIG	1%			
Generator1Temp2	Viklingstemp. Gen1 måling2	°C		ANSIG	1%			
Generator1Temp3	Viklingstemp. Gen1 måling3	°C		ANSIG	1%			
Generator2RPM	Generator2 omdrejninger	RPM		ANSIG	1%			
Generator2Temp1	Viklingstemp. Gen2 måling1	°C		ANSIG	1%			
Generator2Temp2	Viklingstemp. Gen2 måling2	°C		ANSIG	1%			
Generator2Temp3	Viklingstemp. Gen2 måling3	°C		ANSIG	1%			
HSBearingTemp	Geartemp. HS-leje	°C		ANSIG	1%			
HSGen1Temp	Temp. HS-leje gen1	°C		ANSIG	1%			
HSGen2Temp	Temp. HS-leje gen2	°C		ANSIG	1%			
HydraulicPres	Hydrauliktryk	Bar		ANSIG	1%			
HydraulicTemp	Hydrauliktemperatur	°C		ANSIG	1%			
L1Current	Strøm fase1 LV	A		ANSIG	1%			

Name (SignalID)	Description	Unit	Value	Kind	Accuracy	Priority	Time tag	Remark.
L1Voltage	Spænding fase1 LV	V		ANSIG	1%			
L2Current	Strøm fase2 LV	A		ANSIG	1%			
L2Voltage	Spænding fase2 LV	V		ANSIG	1%			
L3Current	Strøm fase3 LV	A		ANSIG	1%			
L3Voltage	Spænding fase3 LV	V		ANSIG	1%			
LSBearingTemp	Geartemp. LS-leje	°C		ANSIG	1%			
MainBearingTemp	Hovedlejetemperatur	°C		ANSIG	1%			
MSBearingTemp	Geartemp. MS-leje	°C		ANSIG	1%			
NacelleHumid	Kabine luftfugtighed	%RH		ANSIG	1%			
NacelleTemp	Kabinetemperatur	°C		ANSIG	1%			
ReactivePower	Reaktiv effekt	kVAr		ANSIG	1%			
RotorPosition	Rotorpos. refererende til blad1	°		ANSIG	1%			
RotorRPM	Rotoromdrejninger	RPM		ANSIG	1%			
TanFi	Tg ϕ -værdi			ANSIG	1%			
WindSpeed	Vindhastighed (lokalt)	m/s		ANSIG	1%			
YawAngle	Krøjevinkel	°		ANSIG	1%			
YawError	Krøjefejl	°		ANSIG	1%			
YawMotor1Temp	Viklingstemp. Krøjedrev1	°C		ANSIG	1%			
YawMotor2Temp	Viklingstemp. Krøjedrev2	°C		ANSIG	1%			
<u>Low priority signals - set points</u>								
SetWTReactivePower	Setpunkt absolut kVAr	kVAr		SETP	1%	LO		
SetWTRotorPosition	Rotorpos. refererende til blad1	°		SETP	1%	LO		
SetWTFlicker	Setpunkt for flicker-regulering	-		SETP	1%	LO		
SetWTTanFi	Setpunkt tg ϕ	-		SETP	1%	LO		
SetWTCosFi	Setpunkt cos ϕ	-		SETP	1%	LO		
<u>High priority signals - set points</u>								
SetWTPower	Setpunkt absolut aktiv effekt	kW		SETP	1%	HI		
SetWTPctPower	Setpunkt relativ aktiv effekt	%		SETP	1%	HI		Relative to potential (kW)
<u>Status (binary)</u>								
AutoRewind	Undertilstand: Udsnoning pågår	"True"		BINSIG			Date+time	Counter +1 on shift to true
AutoRewind	Undertilstand: Udsnoning inaktiv	"False"		BINSIG			Date+time	
AwaitingAutoReset	Undertilstand: Afventer auto-reset	"True"		BINSIG			Date+time	Counter +1 on shift to true
AwaitingAutoReset	Undertilstand: Afventer ikke auto-reset	"False"		BINSIG			Date+time	
AwaitingAutoRewind	Undertilstand: Udsnoning afventes	"True"		BINSIG			Date+time	Counter +1 on shift to true

Name (SignalID)	Description	Unit	Value	Kind	Accuracy	Priority	Time tag	Remark.
AwaitingAutoRewind	Undertilstand: Udsnoning ikke påkrævet	"False"		BINSIG			Date+time	
AwaitingManualReset	Undertilstand: Afventer manuelt reset	"True"		BINSIG			Date+time	Counter +1 on shift to true
AwaitingManualReset	Undertilstand: Afventer ikke manuelt reset	"False"		BINSIG			Date+time	
AwaitingRemoteReset	Undertilstand: Afventer fjernreset	"True"		BINSIG			Date+time	Counter +1 on shift to true
AwaitingRemoteReset	Undertilstand: Afventer ikke fjernreset	"False"		BINSIG			Date+time	
AwaitingTimeDelay	Undertilstand: Afventer udløb af tidsforsinkelse	"True"		BINSIG			Date+time	Counter +1 on shift to true
AwaitingTimeDelay	Undertilstand: Afventer ikke tidsforsinkelse	"False"		BINSIG			Date+time	
ExternalFault	Undertilstand: Ekstern fejl	"True"		BINSIG			Date+time	Counter +1 on shift to true
ExternalFault	Undertilstand: Ingen eksterne fejl	"False"		BINSIG			Date+time	
HighWind	Undertilstand: Vindhastighed for høj	"True"		BINSIG			Date+time	Counter +1 on shift to true
HighWind	Undertilstand: Vindhastighed ikke for høj	"False"		BINSIG			Date+time	
Idling	Hovedtilstand: Friløb	"True"		BINSIG			Date+time	Counter +1 on shift to true
Idling	Hovedtilstand: Ikke i Friløb	"False"		BINSIG			Date+time	
InternalFault	Undertilstand: Vindmøllefejl	"True"		BINSIG			Date+time	Counter +1 on shift to true
InternalFault	Undertilstand: Ingen vindmøllefejl	"False"		BINSIG			Date+time	
IsolatedOperation	Undertilstand: Autonom drift aktiv	"True"		BINSIG			Date+time	Counter +1 on shift to true
IsolatedOperation	Undertilstand: Koordineret drift aktiv	"False"		BINSIG			Date+time	
ManualMode	Undertilstand: Manuel betjening aktiv	"True"		BINSIG			Date+time	Counter +1 on shift to true
ManualMode	Undertilstand: Manuel betjening inaktiv	"False"		BINSIG			Date+time	
NacelleOutOfWind	Undertilstand: Kabine ikke krøjet op i vinden	"True"		BINSIG			Date+time	Counter +1 on shift to true
NacelleOutOfWind	Undertilstand: Kabine krøjet op i vinden	"False"		BINSIG			Date+time	
Operation	Hovedtilstand: Drift	"True"		BINSIG			Date+time	Counter +1 on shift to true
Operation	Hovedtilstand: Ikke i Drift	"False"		BINSIG			Date+time	
OperationAccepted	Undertilstand: Frigivet til at producere	"True"		BINSIG			Date+time	Counter +1 on shift to true
OperationAccepted	Undertilstand: Ikke frigivet til at producere	"False"		BINSIG			Date+time	
ShutDown	Hovedtilstand: Afbrudt	"True"		BINSIG			Date+time	Counter +1 on shift to true
ShutDown	Hovedtilstand: Ikke Afbrudt	"False"		BINSIG			Date+time	
Stopped	Hovedtilstand: Parkeret	"True"		BINSIG			Date+time	Counter +1 on shift to true
Stopped	Hovedtilstand: Ikke Parkeret	"False"		BINSIG			Date+time	
SystemFault	Undertilstand: Systemfejl	"True"		BINSIG			Date+time	Counter +1 on shift to true
SystemFault	Undertilstand: Ingen systemfejl	"False"		BINSIG			Date+time	
YawingAccepted	Undertilstand: Frigivet til at krøje	"True"		BINSIG			Date+time	Counter +1 on shift to true
YawingAccepted	Undertilstand: Ikke frigivet til at krøje	"False"		BINSIG			Date+time	
Binary signals								
BalanceRegOn	Balanceregulering aktiveret centralt	"True"	1	BINSIG				

Name (SignalID)	Description	Unit	Value	Kind	Accuracy	Priority	Time tag	Remark.
BalanceRegOn	Balanceregulering deaktiveret centralt	"False"	0	BINSIG				
BladeBrakeOn	Vingebremse aktiveret	"True"	1	BINSIG				
BladeBrakeOn	Vingebremse deaktiveret	"False"	0	BINSIG				
Compensation1On	Reaktivkompensering trin1aktiv	"True"	1	BINSIG				
Compensation1On	Reaktivkompensering trin1inaktiv	"False"	0	BINSIG				
Compensation2On	Reaktivkompensering trin2aktiv	"True"	1	BINSIG				
Compensation2On	Reaktivkompensering trin2inaktiv	"False"	0	BINSIG				
CompensationOn	Reaktivkompensering aktiv	"True"	1	BINSIG				
CompensationOn	Reaktivkompensering inaktiv	"False"	0	BINSIG				
CosFiRegOn	Regulering efter cos <input type="checkbox"/> -reference aktiv	"True"	1	BINSIG				
CosFiRegOn	Regulering efter cos <input type="checkbox"/> -reference inaktiv	"False"	0	BINSIG				
DiscBrakeOn	Skivebremse aktiveret	"True"	1	BINSIG				
DiscBrakeOn	Skivebremse deaktiveret	"False"	0	BINSIG				
EmergencyStopOn	Manuelt nødstoptryk aktiveret	"True"	1	BINSIG				
EmergencyStopOn	Manuelt nødstoptryk deaktiveret	"False"	0	BINSIG				
FlickerRegOn	Flicker-regulering aktiv	"True"	1	BINSIG				
FlickerRegOn	Flicker-regulering inaktiv	"False"	0	BINSIG				
FreqRegOn	Frekvensregulering aktiv	"True"	1	BINSIG				
FreqRegOn	Frekvensregulering inaktiv	"False"	0	BINSIG				
GearOilFilterOn	Gearoliefiltervagt aktiv	"True"	1	BINSIG				
GearOilFilterOn	Gearoliefiltervagt inaktiv	"False"	0	BINSIG				
GearOilFlowOn	Gearolieflowvagt aktiv	"True"	1	BINSIG				
GearOilFlowOn	Gearolieflowvagt inaktiv	"False"	0	BINSIG				
GearOilMagnetOn	Gearoliemagnetvagt aktiv	"True"	1	BINSIG				
GearOilMagnetOn	Gearoliemagnetvagt inaktiv	"False"	0	BINSIG				
GearOilPumpOn	Gearoliepumpe aktiv	"True"	1	BINSIG				
GearOilPumpOn	Gearoliepumpe inaktiv	"False"	0	BINSIG				
GearOilPumpThermalOut	Gearoliepumpe termisk inde	"True"	1	BINSIG				
GearOilPumpThermalOut	Gearoliepumpe termisk ude	"False"	0	BINSIG				
Gen1MagneticOut	Generator1 magnetisk inde (maks-afbr.)	"True"	1	BINSIG				
Gen1MagneticOut	Generator1 magnetisk ude (maks-afbr.)	"False"	0	BINSIG				
Gen1ThermalOut	Generator1 termisk inde (maks-afbr.)	"True"	1	BINSIG				
Gen1ThermalOut	Generator1 termisk ude (maks-afbr.)	"False"	0	BINSIG				
Gen2MagneticOut	Generator2 magnetisk inde (maks-afbr.)	"True"	1	BINSIG				
Gen2MagneticOut	Generator2 magnetisk ude (maks-afbr.)	"False"	0	BINSIG				

Name (SignalID)	Description	Unit	Value	Kind	Accuracy	Priority	Time tag	Remark.
Gen2ThermalOut	Generator2 termisk inde (maks-afbr.)	"True"	1	BINSIG				
Gen2ThermalOut	Generator2 termisk ude (maks-afbr.)	"False"	0	BINSIG				
GenCoolingFlowOn	Generatorkøleflowvagt aktiv	"True"	1	BINSIG				
GenCoolingFlowOn	Generatorkøleflowvagt inaktiv	"False"	0	BINSIG				
Generator1On	Generator1 indkoblet	"True"	1	BINSIG				
Generator1On	Generator1 udkoblet	"False"	0	BINSIG				
Generator2On	Generator2 indkoblet	"True"	1	BINSIG				
Generator2On	Generator2 udkoblet	"False"	0	BINSIG				
GeneratorCoolingOn	Generatorblæser el. kølepumpe aktiv	"True"	1	BINSIG				
GeneratorCoolingOn	Generatorblæser el. kølepumpe inaktiv	"False"	0	BINSIG				
GradientRegOn	Gradientbegrænsning aktiv	"True"	1	BINSIG				
GradientRegOn	Gradientbegrænsning inaktiv	"False"	0	BINSIG				
HubArrestOn	Navarretering aktiveret	"True"	1	BINSIG				
HubArrestOn	Navarretering deaktiveret	"False"	0	BINSIG				
HydraulicPumpOn	Hydraulikpumpe aktiv	"True"	1	BINSIG				
HydraulicPumpOn	Hydraulikpumpe inaktiv	"False"	0	BINSIG				
KVArRegOn	Regulering efter kVAr-reference aktiv	"True"	1	BINSIG				
KVArRegOn	Regulering efter kVAr-reference inaktiv	"False"	0	BINSIG				
LocalReactivePowerRefOn	Lokal reaktiv effektreference aktiv	"True"	1	BINSIG				
LocalReactivePowerRefOn	Lokal reaktiv effektreference inaktiv	"False"	0	BINSIG				
LVCircuitBreakerOn	Lavspændingsmaksimalafbryder inde	"True"	1	BINSIG				
LVCircuitBreakerOn	Lavspændingsmaksimalafbryder ude	"False"	0	BINSIG				
MVCircuitBreakerOn	Effektafbryder i trafofelt inde	"True"	1	BINSIG				
MVCircuitBreakerOn	Effektafbryder i trafofelt ude	"False"	0	BINSIG				
ProductionLimitOn	Produktionsbegrænsning aktiv	"True"	1	BINSIG				
ProductionLimitOn	Produktionsbegrænsning inaktiv	"False"	0	BINSIG				
RemoteControlOn	Fjernkommandoer afbrudt	"True"	1	BINSIG				
RemoteControlOn	Fjernkommandoer tilladt	"False"	0	BINSIG				
RemotePowerRefOn	Aktiv effektreference aktiveret centralt	"True"	1	BINSIG				
RemotePowerRefOn	Aktiv effektreference deaktiveret centralt	"False"	0	BINSIG				
RemoteReactivePowerRefOn	Central reaktiv effektreference aktiveret	"True"	1	BINSIG				
RemoteReactivePowerRefOn	Central reaktiv effektreference deaktiveret	"False"	0	BINSIG				
TanFiRegOn	Regulering efter tg ϕ -reference aktiv	"True"	1	BINSIG				
TanFiRegOn	Regulering efter tg ϕ -reference inaktiv	"False"	0	BINSIG				
VibrationSensorOn	Vibrationssensor aktiveret	"True"	1	BINSIG				

Name (SignalID)	Description	Unit	Value	Kind	Accuracy	Priority	Time tag	Remark.
VibrationSensorOn	Vibrationssensor deaktiveret	"False"	0	BINSIG				
YawArrestOn	Krøjearretering aktiveret	"True"	1	BINSIG				
YawArrestOn	Krøjearretering deaktiveret	"False"	0	BINSIG				
YawCCWRequestOn	Krøjeegrænse CCW aktiveret	"True"	1	BINSIG				
YawCCWRequestOn	Krøjeegrænse CCW deaktiveret	"False"	0	BINSIG				
YawCWRequestOn	Krøjeegrænse CW aktiveret	"True"	1	BINSIG				
YawCWRequestOn	Krøjeegrænse CW deaktiveret	"False"	0	BINSIG				
YawDriveCCWOn	Krøjedrev CCW-retning aktiv	"True"	1	BINSIG				
YawiDriveCCWOn	Krøjedrev CCW-retning inaktiv	"False"	0	BINSIG				
YawiDriveCWOOn	Krøjedrev CW-retning aktiv	"True"	1	BINSIG				
YawiDriveCWOOn	Krøjedrev CW-retning inaktiv	"False"	0	BINSIG				
<u>Low priority signals - instructions</u>								
WTBalanceRegOff	Balanceregulering deaktiveret centralt	"True"		BINCOM		LO	Date+time	Counter +1 on shift to true
WTBalanceRegOn	Balanceregulering aktiveret centralt	"True"		BINCOM		LO	Date+time	Counter +1 on shift to true
WTCompOff	Afbrydelse af reaktiv kompensering	"True"		BINCOM		LO	Date+time	Counter +1 on shift to true
WTCompOn	Aktivering af reaktiv kompensering	"True"		BINCOM		LO	Date+time	Counter +1 on shift to true
WTCosFiRegOff	Regulering efter cos \square -reference fra	"True"		BINCOM		LO	Date+time	Counter +1 on shift to true
WTCosFiRegOn	Regulering efter cos \square -reference til	"True"		BINCOM		LO	Date+time	Counter +1 on shift to true
WTErrrorReset	Kvittering af vindmøllefejl	"True"		BINCOM		LO	Date+time	Counter +1 on shift to true
WTFlickerRegOff	Flicker-regulering deaktiveret centralt	"True"		BINCOM		LO	Date+time	Counter +1 on shift to true
WTFlickerRegOn	Flicker-regulering aktiveret centralt	"True"		BINCOM		LO	Date+time	Counter +1 on shift to true
WTFreqRegOff	Frekvensregulering deaktiveret centralt	"True"		BINCOM		LO	Date+time	Counter +1 on shift to true
WTFreqRegOn	Frekvensregulering aktiveret centralt	"True"		BINCOM		LO	Date+time	Counter +1 on shift to true
WTGradientRegOff	Gradientbegrænsning deaktiveret centralt	"True"		BINCOM		LO	Date+time	Counter +1 on shift to true
WTGradientRegOn	Gradientbegrænsning aktiveret centralt	"True"		BINCOM		LO	Date+time	Counter +1 on shift to true
WTIdle	Vindmøllen frigives/tvinges til "friløb"	"True"		BINCOM		LO	Date+time	Counter +1 on shift to true
WTKVArRegOff	Regulering efter kVAr-reference fra	"True"		BINCOM		LO	Date+time	Counter +1 on shift to true
WTKVArRegOn	Regulering efter kVAr-reference	"True"		BINCOM		LO	Date+time	Counter +1 on shift to true
WTProductionLimitOff	Produktionsbegrænsning deaktiveret centralt	"True"		BINCOM		LO	Date+time	Counter +1 on shift to true
WTProductionLimitOn	Produktionsbegrænsning aktiveret centralt	"True"		BINCOM		LO	Date+time	Counter +1 on shift to true
WTTanFiRegOff	Regulering efter tg ϕ -reference fra	"True"		BINCOM		LO	Date+time	Counter +1 on shift to true
WTTanFiRegOn	Regulering efter tg ϕ -reference	"True"		BINCOM		LO	Date+time	Counter +1 on shift to true
WTYawDriveCCWOn	Krøjedrev CCW-retning aktiv	"True"		BINCOM		LO	Date+time	Counter +1 on shift to true
WTYawiDriveCCWOn	Krøjedrev CCW-retning inaktiv	"True"		BINCOM		LO	Date+time	Counter +1 on shift to true

Name (SignalID)	Description	Unit	Value	Kind	Accuracy	Priority	Time tag	Remark.
WTYawiDriveCWOon	Krøjedrev CW-retning inaktiv	"True"		BINCOM		LO	Date+time	Counter +1 on shift to true
WTYawiDriveCWOon	Krøjedrev CW-retning aktiv	"True"		BINCOM		LO	Date+time	Counter +1 on shift to true
<u>High priority signals - binary commands</u>								
WTLVCircuitBreakerOff	Udkobling af lavspændingsmaksimalafbryder	"True"		BINCOM		HI	Date+time	Counter +1 on shift to true
WTLVCircuitBreakerOn	Indkobling af lavspændingsmaksimalafbryder	"True"		BINCOM		HI	Date+time	Counter +1 on shift to true
WTMVCircuitBreakerOff	Udkobling af effektafbryder i trafofelt	"True"		BINCOM		HI	Date+time	Counter +1 on shift to true
WTMVCircuitBreakerOn	Indkobling af effektafbryder i trafofelt	"True"		BINCOM		HI	Date+time	Counter +1 on shift to true
WTRemotePowerRefOff	Aktiv central effektreference deaktiveret	"True"		BINCOM		HI	Date+time	Counter +1 on shift to true
WTRemotePowerRefOn	Aktiv central effektreference aktiveret	"True"		BINCOM		HI	Date+time	Counter +1 on shift to true
WTStart	Vindmøllen frigives/tillades skift til "drift"	"True"		BINCOM		HI	Date+time	Counter +1 on shift to true
WTStop	Vindmøllen tvinges til "parkeret" tilstand	"True"		BINCOM		HI	Date+time	Counter +1 on shift to true
<u>Alarms and alarm log</u>								
WTErrrorXXXX	Aktiv effekt større end reference	"True"		AL			Date+time	Counter +1 on shift to true
WTErrrorXXXX	Aktiv effekt større end reference	"Reset"		AL			Date+time	
WTErrrorXXXX	Aktiv effektregering fejlrant	"True"		AL			Date+time	Counter +1 on shift to true
WTErrrorXXXX	Aktiv effektregering fejlrant	"Reset"		AL			Date+time	
WTErrrorXXXX	Balanceregering fejlrant	"True"		AL			Date+time	Counter +1 on shift to true
WTErrrorXXXX	Balanceregering fejlrant	"Reset"		AL			Date+time	
WTErrrorXXXX	Bladvinkel udenfor reference	"True"		AL			Date+time	Counter +1 on shift to true
WTErrrorXXXX	Bladvinkel udenfor reference	"Reset"		AL			Date+time	
WTErrrorXXXX	Bremeslid	"True"		AL			Date+time	Counter +1 on shift to true
WTErrrorXXXX	Bremeslid	"Reset"		AL			Date+time	
WTErrrorXXXX	Cos \square -regulering fejlrant	"True"		AL			Date+time	Counter +1 on shift to true
WTErrrorXXXX	Cos \square -regulering fejlrant	"Reset"		AL			Date+time	
WTErrrorXXXX	Cos \square -værdi udenfor reference	"True"		AL			Date+time	Counter +1 on shift to true
WTErrrorXXXX	Cos \square -værdi udenfor reference	"Reset"		AL			Date+time	
WTErrrorXXXX	Effektafbryder i trafofelt ude	"True"		AL			Date+time	Counter +1 on shift to true
WTErrrorXXXX	Effektafbryder i trafofelt ude	"Reset"		AL			Date+time	
WTErrrorXXXX	Eksternt system fejlrant	"True"		AL			Date+time	Counter +1 on shift to true
WTErrrorXXXX	Eksternt system fejlrant	"Reset"		AL			Date+time	
WTErrrorXXXX	Flicker-regulering fejlrant	"True"		AL			Date+time	Counter +1 on shift to true
WTErrrorXXXX	Flicker-regulering fejlrant	"Reset"		AL			Date+time	
WTErrrorXXXX	Frekvensregulering fejlrant	"True"		AL			Date+time	Counter +1 on shift to true
WTErrrorXXXX	Frekvensregulering fejlrant	"Reset"		AL			Date+time	

Name (SignalID)	Description	Unit	Value	Kind	Accuracy	Priority	Time tag	Remark.
WTErrorXXXX	Gearoliefiltervagt aktiveret	"True"		AL			Date+time	Counter +1 on shift to true
WTErrorXXXX	Gearoliefiltervagt aktiveret	"Reset"		AL			Date+time	
WTErrorXXXX	Gearolieflowvagt aktiveret	"True"		AL			Date+time	Counter +1 on shift to true
WTErrorXXXX	Gearolieflowvagt aktiveret	"Reset"		AL			Date+time	
WTErrorXXXX	Gearoliemagnetvagt aktiveret	"True"		AL			Date+time	Counter +1 on shift to true
WTErrorXXXX	Gearoliemagnetvagt aktiveret	"Reset"		AL			Date+time	
WTErrorXXXX	Gearoliepumpe termisk ude	"True"		AL			Date+time	Counter +1 on shift to true
WTErrorXXXX	Gearoliepumpe termisk ude	"Reset"		AL			Date+time	
WTErrorXXXX	Geartemp. HS-leje høj	"True"		AL			Date+time	Counter +1 on shift to true
WTErrorXXXX	Geartemp. HS-leje høj	"Reset"		AL			Date+time	
WTErrorXXXX	Geartemp. LS-leje høj	"True"		AL			Date+time	Counter +1 on shift to true
WTErrorXXXX	Geartemp. LS-leje høj	"Reset"		AL			Date+time	
WTErrorXXXX	Geartemp. MS-leje høj	"True"		AL			Date+time	Counter +1 on shift to true
WTErrorXXXX	Geartemp. MS-leje høj	"Reset"		AL			Date+time	
WTErrorXXXX	Generator1 magnetisk ude (maks-afbr.)	"True"		AL			Date+time	Counter +1 on shift to true
WTErrorXXXX	Generator1 magnetisk ude (maks-afbr.)	"Reset"		AL			Date+time	
WTErrorXXXX	Generator1 overomdrejninger	"True"		AL			Date+time	Counter +1 on shift to true
WTErrorXXXX	Generator1 overomdrejninger	"Reset"		AL			Date+time	
WTErrorXXXX	Generator1 termisk ude (maks-afbr.)	"True"		AL			Date+time	Counter +1 on shift to true
WTErrorXXXX	Generator1 termisk ude (maks-afbr.)	"Reset"		AL			Date+time	
WTErrorXXXX	Generator2 magnetisk ude (maks-afbr.)	"True"		AL			Date+time	Counter +1 on shift to true
WTErrorXXXX	Generator2 magnetisk ude (maks-afbr.)	"Reset"		AL			Date+time	
WTErrorXXXX	Generator2 overomdrejninger	"True"		AL			Date+time	Counter +1 on shift to true
WTErrorXXXX	Generator2 overomdrejninger	"Reset"		AL			Date+time	
WTErrorXXXX	Generator2 termisk ude (maks-afbr.)	"True"		AL			Date+time	Counter +1 on shift to true
WTErrorXXXX	Generator2 termisk ude (maks-afbr.)	"Reset"		AL			Date+time	
WTErrorXXXX	Generatorkøleflowvagt aktiveret	"True"		AL			Date+time	Counter +1 on shift to true
WTErrorXXXX	Generatorkøleflowvagt aktiveret	"Reset"		AL			Date+time	
WTErrorXXXX	Hovedlejetemperatur høj	"True"		AL			Date+time	Counter +1 on shift to true
WTErrorXXXX	Hovedlejetemperatur høj	"Reset"		AL			Date+time	
WTErrorXXXX	Hydraulikpumpe termisk ude	"True"		AL			Date+time	Counter +1 on shift to true
WTErrorXXXX	Hydraulikpumpe termisk ude	"Reset"		AL			Date+time	
WTErrorXXXX	Hydrauliktemperatur høj	"True"		AL			Date+time	Counter +1 on shift to true
WTErrorXXXX	Hydrauliktemperatur høj	"Reset"		AL			Date+time	
WTErrorXXXX	Hydrauliktryk lavt	"True"		AL			Date+time	Counter +1 on shift to true

Name (SignalID)	Description	Unit	Value	Kind	Accuracy	Priority	Time tag	Remark.
WTErrrorXXXX	Hydrauliktryk lavt	"Reset"		AL			Date+time	
WTErrrorXXXX	Kabine luftfugtighed høj	"True"		AL			Date+time	Counter +1 on shift to true
WTErrrorXXXX	Kabine luftfugtighed høj	"Reset"		AL			Date+time	
WTErrrorXXXX	Kabinettemperatur høj	"True"		AL			Date+time	Counter +1 on shift to true
WTErrrorXXXX	Kabinettemperatur høj	"Reset"		AL			Date+time	
WTErrrorXXXX	Kommunikationsfejl eksternt	"True"		AL			Date+time	Counter +1 on shift to true
WTErrrorXXXX	Kommunikationsfejl eksternt	"Reset"		AL			Date+time	
WTErrrorXXXX	Kommunikationsfejl internt	"True"		AL			Date+time	Counter +1 on shift to true
WTErrrorXXXX	Kommunikationsfejl internt	"Reset"		AL			Date+time	
WTErrrorXXXX	Krøjedrev termisk ude	"True"		AL			Date+time	Counter +1 on shift to true
WTErrrorXXXX	Krøjedrev termisk ude	"Reset"		AL			Date+time	
WTErrrorXXXX	Krøje fejl stor	"True"		AL			Date+time	Counter +1 on shift to true
WTErrrorXXXX	Krøje fejl stor	"Reset"		AL			Date+time	
WTErrrorXXXX	Kølemediepumpe termisk ude	"True"		AL			Date+time	Counter +1 on shift to true
WTErrrorXXXX	Kølemediepumpe termisk ude	"Reset"		AL			Date+time	
WTErrrorXXXX	Kølemedietemp. Gen1 ind høj	"True"		AL			Date+time	Counter +1 on shift to true
WTErrrorXXXX	Kølemedietemp. Gen1 ind høj	"Reset"		AL			Date+time	
WTErrrorXXXX	Kølemedietemp. Gen1 ud høj	"True"		AL			Date+time	Counter +1 on shift to true
WTErrrorXXXX	Kølemedietemp. Gen1 ud høj	"Reset"		AL			Date+time	
WTErrrorXXXX	Kølemedietemp. Gen2 ind høj	"True"		AL			Date+time	Counter +1 on shift to true
WTErrrorXXXX	Kølemedietemp. Gen2 ind høj	"Reset"		AL			Date+time	
WTErrrorXXXX	Kølemedietemp. Gen2 ud høj	"True"		AL			Date+time	Counter +1 on shift to true
WTErrrorXXXX	Kølemedietemp. Gen2 ud høj	"Reset"		AL			Date+time	
WTErrrorXXXX	Luftafmærkningssystem fejlramt	"True"		AL			Date+time	Counter +1 on shift to true
WTErrrorXXXX	Luftafmærkningssystem fejlramt	"Reset"		AL			Date+time	
WTErrrorXXXX	LV-afbryder ude	"True"		AL			Date+time	Counter +1 on shift to true
WTErrrorXXXX	LV-afbryder ude	"Reset"		AL			Date+time	
WTErrrorXXXX	Maksimalafbryder udløst af Styresystem	"True"		AL			Date+time	Counter +1 on shift to true
WTErrrorXXXX	Maksimalafbryder udløst af Styresystem	"Reset"		AL			Date+time	
WTErrrorXXXX	Manuelt nødstoptryk aktiveret	"True"		AL			Date+time	Counter +1 on shift to true
WTErrrorXXXX	Manuelt nødstoptryk aktiveret	"Reset"		AL			Date+time	
WTErrrorXXXX	Måling udenfor område	"True"		AL			Date+time	Counter +1 on shift to true
WTErrrorXXXX	Måling udenfor område	"Reset"		AL			Date+time	
WTErrrorXXXX	Netfrekvens (lokalt) udenfor område	"True"		AL			Date+time	Counter +1 on shift to true
WTErrrorXXXX	Netfrekvens (lokalt) udenfor område	"Reset"		AL			Date+time	

Name (SignalID)	Description	Unit	Value	Kind	Accuracy	Priority	Time tag	Remark.
WTErrorXXXX	Nødforsyningsystem fejlramt	"True"		AL			Date+time	Counter +1 on shift to true
WTErrorXXXX	Nødforsyningsystem fejlramt	"Reset"		AL			Date+time	
WTErrorXXXX	Reaktiv effekt udenfor reference	"True"		AL			Date+time	Counter +1 on shift to true
WTErrorXXXX	Reaktiv effekt udenfor reference	"Reset"		AL			Date+time	
WTErrorXXXX	Reaktiv effekregulering fejlramt (kVAr-ref.)	"True"		AL			Date+time	Counter +1 on shift to true
WTErrorXXXX	Reaktiv effekregulering fejlramt (kVAr-ref.)	"Reset"		AL			Date+time	
WTErrorXXXX	Reset af Styresystem eller dele heraf	"True"		AL			Date+time	Counter +1 on shift to true
WTErrorXXXX	Reset af Styresystem eller dele heraf	"Reset"		AL			Date+time	
WTErrorXXXX	Rotoromdrejninger høje	"True"		AL			Date+time	Counter +1 on shift to true
WTErrorXXXX	Rotoromdrejninger høje	"Reset"		AL			Date+time	
WTErrorXXXX	Rotorpos. refererende til blad1udenfor område	"True"		AL			Date+time	Counter +1 on shift to true
WTErrorXXXX	Rotorpos. refererende til blad1udenfor område	"Reset"		AL			Date+time	
WTErrorXXXX	Sikkerhedsstop udløst af Styresystem	"True"		AL			Date+time	Counter +1 on shift to true
WTErrorXXXX	Sikkerhedsstop udløst af Styresystem	"Reset"		AL			Date+time	
WTErrorXXXX	Spænding fase1 LV udenfor område	"True"		AL			Date+time	Counter +1 on shift to true
WTErrorXXXX	Spænding fase1 LV udenfor område	"Reset"		AL			Date+time	
WTErrorXXXX	Spænding fase2 LV udenfor område	"True"		AL			Date+time	Counter +1 on shift to true
WTErrorXXXX	Spænding fase2 LV udenfor område	"Reset"		AL			Date+time	
WTErrorXXXX	Spænding fase3 LV udenfor område	"True"		AL			Date+time	Counter +1 on shift to true
WTErrorXXXX	Spænding fase3 LV udenfor område	"Reset"		AL			Date+time	
WTErrorXXXX	Strøm fase1 LV udenfor område	"True"		AL			Date+time	Counter +1 on shift to true
WTErrorXXXX	Strøm fase1 LV udenfor område	"Reset"		AL			Date+time	
WTErrorXXXX	Strøm fase2 LV udenfor område	"True"		AL			Date+time	Counter +1 on shift to true
WTErrorXXXX	Strøm fase2 LV udenfor område	"Reset"		AL			Date+time	
WTErrorXXXX	Strøm fase3 LV udenfor område	"True"		AL			Date+time	Counter +1 on shift to true
WTErrorXXXX	Strøm fase3 LV udenfor område	"Reset"		AL			Date+time	
WTErrorXXXX	Søafmærkningssystem fejlramt	"True"		AL			Date+time	Counter +1 on shift to true
WTErrorXXXX	Søafmærkningssystem fejlramt	"Reset"		AL			Date+time	
WTErrorXXXX	Temp. HS-leje gen1 høj	"True"		AL			Date+time	Counter +1 on shift to true
WTErrorXXXX	Temp. HS-leje gen1 høj	"Reset"		AL			Date+time	
WTErrorXXXX	Temp. HS-leje gen2 høj	"True"		AL			Date+time	Counter +1 on shift to true
WTErrorXXXX	Temp. HS-leje gen2 høj	"Reset"		AL			Date+time	
WTErrorXXXX	Temp. gear hotspot høj	"True"		AL			Date+time	Counter +1 on shift to true
WTErrorXXXX	Temp. gear hotspot høj	"Reset"		AL			Date+time	
WTErrorXXXX	Temp. køleolie-ind høj	"True"		AL			Date+time	Counter +1 on shift to true

Name (SignalID)	Description	Unit	Value	Kind	Accuracy	Priority	Time tag	Remark.
WTErrorXXXX	Temp. køleolie-ind høj	"True"		AL			Date+time	
WTErrorXXXX	Temp. køleolie-ind høj	"Reset"		AL			Date+time	Counter +1 on shift to true
WTErrorXXXX	Temp. køleolie-ind høj	"Reset"		AL			Date+time	
WTErrorXXXX	Temp. skivebremse/klodser høj	"True"		AL			Date+time	Counter +1 on shift to true
WTErrorXXXX	Temp. skivebremse/klodser høj	"Reset"		AL			Date+time	
WTErrorXXXX	Tg ϕ -værdi udenfor reference	"True"		AL			Date+time	Counter +1 on shift to true
WTErrorXXXX	Tg ϕ -værdi udenfor reference	"Reset"		AL			Date+time	
WTErrorXXXX	Tg \square -regulering fejlramt	"True"		AL			Date+time	Counter +1 on shift to true
WTErrorXXXX	Tg \square -regulering fejlramt	"Reset"		AL			Date+time	
WTErrorXXXX	Vibrationssensor aktiveret	"True"		AL			Date+time	Counter +1 on shift to true
WTErrorXXXX	Vibrationssensor aktiveret	"Reset"		AL			Date+time	
WTErrorXXXX	Viklingstemp. Gen1 måling1 høj	"True"		AL			Date+time	Counter +1 on shift to true
WTErrorXXXX	Viklingstemp. Gen1 måling1 høj	"Reset"		AL			Date+time	
WTErrorXXXX	Viklingstemp. Gen1 måling2 høj	"True"		AL			Date+time	Counter +1 on shift to true
WTErrorXXXX	Viklingstemp. Gen1 måling2 høj	"Reset"		AL			Date+time	
WTErrorXXXX	Viklingstemp. Gen1 måling3 høj	"True"		AL			Date+time	Counter +1 on shift to true
WTErrorXXXX	Viklingstemp. Gen1 måling3 høj	"Reset"		AL			Date+time	
WTErrorXXXX	Viklingstemp. Gen2 måling1 høj	"True"		AL			Date+time	Counter +1 on shift to true
WTErrorXXXX	Viklingstemp. Gen2 måling1 høj	"Reset"		AL			Date+time	
WTErrorXXXX	Viklingstemp. Gen2 måling2 høj	"True"		AL			Date+time	Counter +1 on shift to true
WTErrorXXXX	Viklingstemp. Gen2 måling2 høj	"Reset"		AL			Date+time	
WTErrorXXXX	Viklingstemp. Gen2 måling3 høj	"True"		AL			Date+time	Counter +1 on shift to true
WTErrorXXXX	Viklingstemp. Gen2 måling3 høj	"Reset"		AL			Date+time	
WTErrorXXXX	Viklingstemp. Krøjedrev1 høj	"True"		AL			Date+time	Counter +1 on shift to true
WTErrorXXXX	Viklingstemp. Krøjedrev1 høj	"Reset"		AL			Date+time	
WTErrorXXXX	Viklingstemp. Krøjedrev2 høj	"True"		AL			Date+time	Counter +1 on shift to true
WTErrorXXXX	Viklingstemp. Krøjedrev2 høj	"Reset"		AL			Date+time	
Event log								
WTLogXXXX	Fjernkvittering foretaget	"True"		EV			Date+time	Counter +1 on shift to true
WTLogXXXX	Fjernpause udført	"True"		EV			Date+time	Counter +1 on shift to true
WTLogXXXX	Fjernstart udført	"True"		EV			Date+time	Counter +1 on shift to true
WTLogXXXX	Fjernstop udført	"True"		EV			Date+time	Counter +1 on shift to true
WTLogXXXX	Manuel kvittering foretaget	"True"		EV			Date+time	Counter +1 on shift to true
WTLogXXXX	Manuel pause udført	"True"		EV			Date+time	Counter +1 on shift to true
WTLogXXXX	Manuel start udført	"True"		EV			Date+time	Counter +1 on shift to true

Name (SignalID)	Description	Unit	Value	Kind	Accuracy	Priority	Time tag	Remark.
WTLogXXXX	Manuel stop udført	"True"		EV			Date+time	Counter +1 on shift to true
WTLogXXXX	Parameterændring foretaget ("Nr.", "Ny værdi")	"True"		EV			Date+time	Counter +1 on shift to true
WTLogXXXX	Servicemode	"True"		EV			Date+time	Counter +1 on shift to true
Counters - number of activations								
CountBalanceRegOn	Balanceregulering aktiveret centralt			COU			Date+time	Counter +1 on shift to true
CountBladeBrakeOn	Vingebremse aktiveret			COU			Date+time	Counter +1 on shift to true
CountCompensation1On	Reaktivkompensering trin1aktiv			COU			Date+time	Counter +1 on shift to true
CountCompensation2On	Reaktivkompensering trin2aktiv			COU			Date+time	Counter +1 on shift to true
CountCompensationOn	Reaktivkompensering aktiv			COU			Date+time	Counter +1 on shift to true
CountCosFiRegOn	Regulering efter cos \square -reference aktiv			COU			Date+time	Counter +1 on shift to true
CountDiscBrakeOn	Skivebremse aktiveret			COU			Date+time	Counter +1 on shift to true
CountEmergencyStopOn	Manuelt nødstoptryk aktiveret			COU			Date+time	Counter +1 on shift to true
CountFlickerRegOn	Flicker-regulering aktiv			COU			Date+time	Counter +1 on shift to true
CountFreqRegOn	Frekvensregulering aktiv			COU			Date+time	Counter +1 on shift to true
CountGearOilFilterOn	Gearoliefiltervagt aktiv			COU			Date+time	Counter +1 on shift to true
CountGearOilFlowOn	Gearolieflowvagt aktiv			COU			Date+time	Counter +1 on shift to true
CountGearOilMagnetOn	Gearoliemagnetvagt aktiv			COU			Date+time	Counter +1 on shift to true
CountGearOilPumpOn	Gearoliepumpe aktiv			COU			Date+time	Counter +1 on shift to true
CountGearOilPumpThermalOut	Gearoliepumpe termisk inde			COU			Date+time	Counter +1 on shift to true
CountGen1MagneticOut	Generator1 magnetisk inde (maks-afbr.)			COU			Date+time	Counter +1 on shift to true
CountGen1ThermalOut	Generator1 termisk inde (maks-afbr.)			COU			Date+time	Counter +1 on shift to true
CountGen2MagneticOut	Generator2 magnetisk inde (maks-afbr.)			COU			Date+time	Counter +1 on shift to true
CountGen2ThermalOut	Generator2 termisk inde (maks-afbr.)			COU			Date+time	Counter +1 on shift to true
CountGenCoolingFlowOn	Generatorkøleflowvagt aktiv			COU			Date+time	Counter +1 on shift to true
CountGenerator1On	Generator1 indkoblet			COU			Date+time	Counter +1 on shift to true
CountGenerator2On	Generator2 indkoblet			COU			Date+time	Counter +1 on shift to true
CountGeneratorCoolingOn	Generatorblæser el. kølepumpe aktiv			COU			Date+time	Counter +1 on shift to true
CountGradientRegOn	Gradientbegrænsning aktiv			COU			Date+time	Counter +1 on shift to true
CountHubArrestOn	Navarretering aktiveret			COU			Date+time	Counter +1 on shift to true
CountHydraulicPumpOn	Hydraulikpumpe aktiv			COU			Date+time	Counter +1 on shift to true
CountKVArRegOn	Regulering efter kVAr-reference aktiv			COU			Date+time	Counter +1 on shift to true
CountLocalReactivePowerRefOn	Lokal reaktiv effektreference aktiv			COU			Date+time	Counter +1 on shift to true
CountLVCircuitBreaker On	Lavspændingsmaksimalafbryder inde			COU			Date+time	Counter +1 on shift to true
CountMVCircuitBreakerOn	Effektafbryder i trafofelt inde			COU			Date+time	Counter +1 on shift to true
CountProductionLimitOn	Produktionsbegrænsning aktiv			COU			Date+time	Counter +1 on shift to true

Name (SignalID)	Description	Unit	Value	Kind	Accuracy	Priority	Time tag	Remark.
CountRemoteControlOn	Fjernkommandoer afbrudt			COU			Date+time	Counter +1 on shift to true
CountRemotePowerRefOn	Aktiv effektreference aktiveret centralt			COU			Date+time	Counter +1 on shift to true
CountRemoteReactivePowerRefOn	Central reaktiv effektreference aktiveret			COU			Date+time	Counter +1 on shift to true
CountTanFiRegOn	Regulering efter tg ϕ -reference aktiv			COU			Date+time	Counter +1 on shift to true
CountVibrationSensorOn	Vibrationssensor aktiveret			COU			Date+time	Counter +1 on shift to true
CountYawArrestOn	Krøjearetering aktiveret			COU			Date+time	Counter +1 on shift to true
CountYawCCWRequestOn	Krøjeegrænse CCW aktiveret			COU			Date+time	Counter +1 on shift to true
CountYawCWRequestOn	Krøjeegrænse CW aktiveret			COU			Date+time	Counter +1 on shift to true
CountYawDriveCCWOn	Krøjedrev CCW-retning aktiv			COU			Date+time	Counter +1 on shift to true
CountYawiDriveCWOn	Krøjedrev CW-retning aktiv			COU			Date+time	Counter +1 on shift to true
<u>Production counters</u>								
ProdGen1Total	Totalproduktion generator1	MWh		COU	1		Reset time	
ProdGen2Total	Totalproduktion generator2	MWh		COU	1		Reset time	
ProdPotentialTotal	Potentielle produktion	MWh		COU	1		Reset time	
ProdPotentialSubtotal	Potentielle subtotale produktion	MWh		COU	1		Reset time	
ProdGen1Subtotal	Subtotalproduktion generator1	MWh		COU	1		Reset time	
ProdGen2Subtotal	Subtotalproduktion generator2	MWh		COU	1		Reset time	
<u>Timers (accumulated time)</u>								
TimeAutoRewind	Undertilstand: Udsnoning pågår	Sek		TIM	1		Reset time	
TimeAwaitingAutoReset	Undertilstand: Afventer auto-reset	Sek		TIM	1		Reset time	
TimeAwaitingAutoRewind	Undertilstand: Udsnoning afventes	Sek		TIM	1		Reset time	
TimeAwaitingManualReset	Undertilstand: Afventer manuelt reset	Sek		TIM	1		Reset time	
TimeAwaitingRemoteReset	Undertilstand: Afventer fjernreset	Sek		TIM	1		Reset time	
TimeBalanceRegOn	Balanceregulering aktiveret centralt	Sek		TIM	1		Reset time	
TimeBladeBrakeOn	Vingebremse aktiveret	Sek		TIM	1		Reset time	
TimeCompensation1On	Reaktivkompensering trin1aktiv	Sek		TIM	1		Reset time	
TimeCompensation2On	Reaktivkompensering trin2aktiv	Sek		TIM	1		Reset time	
TimeCompensationOn	Reaktivkompensering aktiv	Sek		TIM	1		Reset time	
TimeCosFiRegOn	Regulering efter cos \square -reference aktiv	Sek		TIM	1		Reset time	
TimeDiscBrakeOn	Skivebremse aktiveret	Sek		TIM	1		Reset time	
TimeEmergencyStopOn	Manuelt nødstoptryk aktiveret	Sek		TIM	1		Reset time	
TimeExternalFault	Undertilstand: Ekstern fejl	Sek		TIM	1		Reset time	
TimeFlickerRegOn	Flicker-regulering aktiv	Sek		TIM	1		Reset time	
TimeFreqRegOn	Frekvensregulering aktiv	Sek		TIM	1		Reset time	
TimeGearOilFilterOn	Gearoliefiltervagt aktiv	Sek		TIM	1		Reset time	

Name (SignalID)	Description	Unit	Value	Kind	Accuracy	Priority	Time tag	Remark.
TimeGearOilFlowOn	Gearolieflowvagt aktiv	Sek		TIM	1		Reset time	
TimeGearOilMagnetOn	Gearoliemagnetvagt aktiv	Sek		TIM	1		Reset time	
TimeGearOilPumpOn	Gearoliepumpe aktiv	Sek		TIM	1		Reset time	
TimeGearOilPumpThermalOut	Gearoliepumpe termisk inde	Sek		TIM	1		Reset time	
TimeGen1MagneticOut	Generator1 magnetisk inde (maks-afbr.)	Sek		TIM	1		Reset time	
TimeGen1Subtotal	Subtotaltid generator1	Sek		TIM	1		Reset time	
TimeGen1ThermalOut	Generator1 termisk inde (maks-afbr.)	Sek		TIM	1		Reset time	
TimeGen2MagneticOut	Generator2 magnetisk inde (maks-afbr.)	Sek		TIM	1		Reset time	
TimeGen2Subtotal	Subtotaltid generator2 indkoblet	Sek		TIM	1		Reset time	
TimeGen2ThermalOut	Generator2 termisk inde (maks-afbr.)	Sek		TIM	1		Reset time	
TimeGenCoolingFlowOn	Generatorkøleflowvagt aktiv	Sek		TIM	1		Reset time	
TimeGenerator1On	Generator1 indkoblet	Sek		TIM	1		Reset time	
TimeGenerator2On	Generator2 indkoblet	Sek		TIM	1		Reset time	
TimeGeneratorCoolingOn	Generatorblæser el. kølepumpe aktiv	Sek		TIM	1		Reset time	
TimeGradientRegOn	Gradientbegrænsning aktiv	Sek		TIM	1		Reset time	
TimeHighWind	Undertilstand: Vindhastighed for høj	Sek		TIM	1		Reset time	
TimeHubArrestOn	Navarretering aktiveret	Sek		TIM	1		Reset time	
TimeHydraulicPumpOn	Hydraulikpumpe aktiv	Sek		TIM	1		Reset time	
TimeIdling	Hovedtilstand: Friløb	Sek		TIM	1		Reset time	
TimeInternalFault	Undertilstand: Vindmøllefejl	Sek		TIM	1		Reset time	
TimeIsolatedOperation	Undertilstand: Autonom drift aktiv	Sek		TIM	1		Reset time	
TimeKVARRegOn	Regulering efter kVAR-reference aktiv	Sek		TIM	1		Reset time	
TimeLocalReactivePowerRefOn	Lokal reaktiv effektreference aktiv	Sek		TIM	1		Reset time	
TimeLVCircuitBreaker On	Lavspændingsmaksimalafbryder inde	Sek		TIM	1		Reset time	
TimeManualMode	Undertilstand: Manuel betjening aktiv	Sek		TIM	1		Reset time	
TimeMVCircuitBreakerOn	Effektafbryder i trafofelt inde	Sek		TIM	1		Reset time	
TimeOperation	Hovedtilstand: Drift	Sek		TIM	1		Reset time	
TimeOperationAccepted	Undertilstand: Frigivet til at producere	Sek		TIM	1		Reset time	
TimeProductionLimitOn	Produktionsbegrænsning aktiv	Sek		TIM	1		Reset time	
TimeRemoteControlOn	Fjernkommandoer afbrudt	Sek		TIM	1		Reset time	
TimeRemotePowerRefOn	Aktiv effektreference aktiveret centralt	Sek		TIM	1		Reset time	
TimeRemoteReactivePowerRefOn	Central reaktiv effektreference aktiveret	Sek		TIM	1		Reset time	
TimeShutDown	Hovedtilstand: Afbrudt	Sek		TIM	1		Reset time	
TimeStopped	Hovedtilstand: Parkeret	Sek		TIM	1		Reset time	
TimeSystemFault	Undertilstand: Systemfejl	Sek		TIM	1		Reset time	

Name (SignalID)	Description	Unit	Value	Kind	Accuracy	Priority	Time tag	Remark.
TimeTanFiRegOn	Regulering efter tg ϕ -reference aktiv	Sek		TIM	1		Reset time	
TimeTotal	Totaltid siden reset	Sek		TIM	1		Reset time	
TimeVibrationSensorOn	Vibrationssensor aktiveret	Sek		TIM	1		Reset time	
TimeWindOK	Tid med tilladt vindhast.	Sek		TIM	1		Reset time	
TimeYawArrestOn	Krøjearretering aktiveret	Sek		TIM	1		Reset time	
TimeYawCCWRequestOn	Krøjeegrænse CCW aktiveret	Sek		TIM	1		Reset time	
TimeYawCWRequestOn	Krøjeegrænse CW aktiveret	Sek		TIM	1		Reset time	
TimeYawDriveCCWOn	Krøjedrev CCW-retning aktiv	Sek		TIM	1		Reset time	
TimeYawiDriveCWOn	Krøjedrev CW-retning aktiv	Sek		TIM	1		Reset time	
TimeYawingAccepted	Undertilstand: Frigivet til at krøje	Sek		TIM	1		Reset time	